



**PRODUCT SERVICE MANUAL
AND
PARTS LIST
FOR
PG12DNSJ-187**



WARNING

This manual, General Installation and Troubleshooting Manual (SRM00046) and Safety Operation Manual should be read thoroughly prior to pump installation, operation and maintenance.

Manual No. SRM00111

Rev. 01 (21-0001)

October, 2021



READ THIS ENTIRE PAGE BEFORE PROCEEDING

FOR SAFETY OF PERSONNEL AND TO PREVENT DAMAGE TO EQUIPMENT, THE FOLLOWING NOMENCLATURE HAS BEEN USED IN THIS MANUAL:

	DANGER	
Failure to observe precautions noted in this box can result in severe bodily injury or loss of life.		

	WARNING	
Failure to observe precautions noted in this box can cause injury to personnel by accidental contact with equipment or liquids. Protection should be provided by user to prevent accidental contact.		

	CAUTION	ATTENTION	
Failure to observe precautions noted in this box can cause damage or failure of equipment.			

Non compliance of safety instructions identified by the following symbol could affect safety for persons:	Safety instructions where electrical safety is involved are identified by:	Safety instructions which shall be considered for reasons of safe operation of pump and/or protection of pump itself are marked by the sign:
		ATTENTION

CONTENTS

Safety and Table of Contents		2
A..... General Instructions		3
B..... Introduction		3
C..... Description of Equipment		3
D..... Pump Model Identification		4
E..... Ordering Instructions		4
F..... Operation		5
G..... Parts List		5
H..... Pump Maintenance		6
I..... Mechanical Seal Drawing		9
J..... Troubleshooting and Field and Factory Service and Parts		10
K..... Assembly Drawings		11

	ATTENTION	
If operation of pump is critical to your business, we strongly recommend you keep a spare pump or major repair kit in stock at all times. As a minimum, a minor repair kit (o-rings, gaskets, shaft seal and bearings) should be kept in stock so pump refurbishment after internal inspection can be accomplished.		

A. GENERAL INSTRUCTIONS

Instructions found herein cover the disassembly, assembly and parts identification of the PG12DNSJ-187.

NOTE: Individual contracts may have specific provisions that vary from this manual. Should any questions arise which may not be answered by these instructions, refer to General Instructions Manual, SRM00046, provided with your order. For further detailed information and technical assistance please refer to Imo Pump, Technical/Customer Service Department, at (704) 289-6511.

This manual cannot possibly cover every situation connected with installation, operation, inspection, and maintenance of equipment supplied. Every effort was made to prepare text of manual so that engineering and design data is transformed into most easily understood wording. Imo Pump must assume personnel assigned to operate and maintain supplied equipment and apply this instruction manual have sufficient technical knowledge and are experienced to apply sound safety and operational practices which may not be otherwise covered by this manual.

In applications where equipment furnished by Imo Pump is to become part of processing machinery, these instructions should be thoroughly reviewed to ensure proper fit of said equipment into overall plant operational procedures.



WARNING

If installation, operation, and maintenance instructions are not correctly and strictly followed and observed, injury to personnel or serious damage to pump could result. Imo Pump cannot accept responsibility for unsatisfactory performance or damage resulting from failure to comply with instructions.

B. INTRODUCTION

This service manual covers PG12DNSJ-187 pumps. This series of pumps has been designed for use in hydraulic, lubricating, seal, distillate, residual, fuel and crude oil applications. The model and design construction of each pump can be identified by the designator code on the pump nameplate. Definitions of model designators are identified in figure 1.

C. DESCRIPTION OF EQUIPMENT

PG12DNSJ-187 pumps are positive displacement, rotary screw pumps consisting of precision bored housings which enclose a driven screw (power rotor) and intermeshing following screws (idler rotors). These screws when rotating form a succession of closures or cavities. As they rotate, fluid is moved axially from inlet port to outlet port in a continuous, uniform flow with minimum fluid pulsation and pump noise.

D. PUMP MODEL IDENTIFICATION

This instruction manual covers PG12DNSJ-187 pumps. Model of each pump is identified on pump nameplate. Refer to figure 1 and table 1 for instructional keys when using this manual.

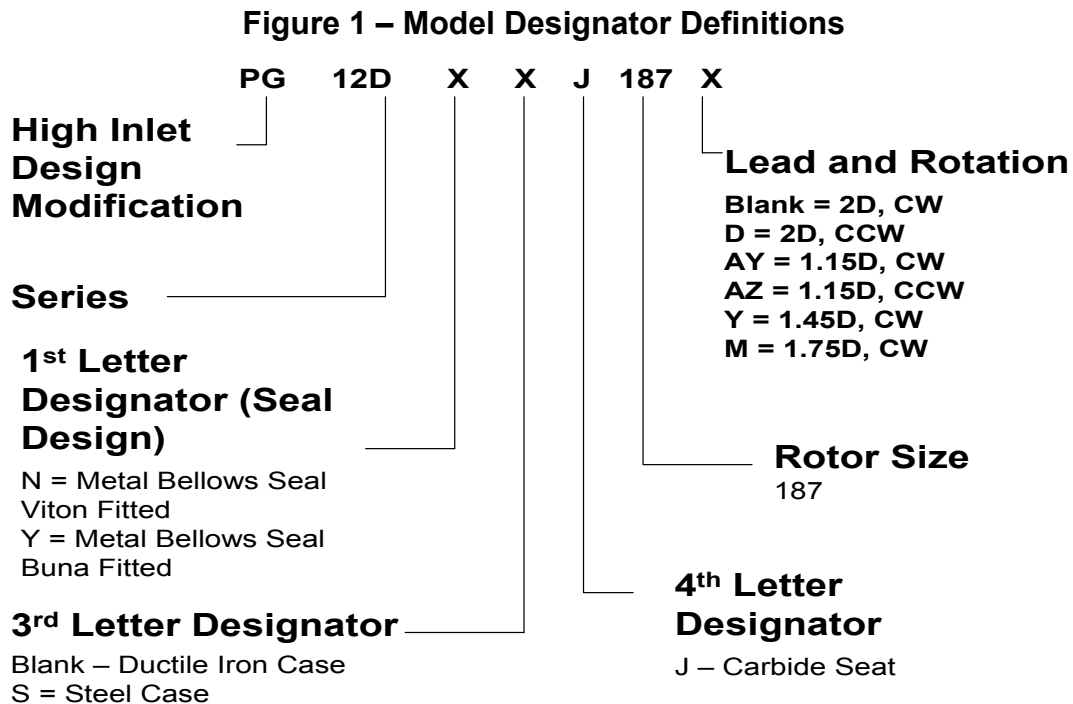

E. ORDERING INSTRUCTIONS

When corresponding with Imo Pump regarding PG12DNSJ-187 pumps, refer to pump nameplate, this instruction manual, and assembly drawing as instructed below:

1. From nameplate, record pump model number, serial number, and manufactured date.
2. Record instruction manual number, revision, and date.
3. From instruction manual, record figure numbers that apply to replacement part(s).
4. From assembly drawing or parts list (see table 2) provide IDP number(s) and names for replacement part(s).
5. Give above information to your Imo service representative.

Imo sales & service representatives are listed herein and in General Instruction Manual, SRM00046.

F. OPERATION

CAUTION	ATTENTION
Never operate with water. Pump is designed for liquids having general characteristics of oil.	

F.1 OPERATING LIMITS

CAUTION	ATTENTION
Operating conditions, such as speed, fluid viscosity, temperature, inlet pressure, discharge pressure, filtration, duty cycle, drive type, mounting, etc., are interrelated. Due to these variable conditions, specific application limits may be different from operational limitations. Equipment must not be operated without verifying system operating requirements are within pump's capabilities.	

Under no circumstances are the following operating limits (specified in table 1) to be exceeded without specific approval from Imo Pump.

Table 1 – Normal Pump Operating and Structural Limits

Condition	Limit
Maximum Speed	3600 Rpm
Viscosity Range	70 – 2000 SSU
Liquid Temperature Range	0° - 200°F
Maximum Inlet Pressure	300 psig
Maximum Discharge Pressure (Continuous Duty)	2250 psig
Filtration	Refer to General Instruction Manual, SRM00046
Drive	Direct
Mounting	Foot mounted in any attitude

G. PARTS LIST

Table 2 – Pump Parts List

IDP	QTY	DESCRIPTION	KIT	IDP	QTY	DESCRIPTION	KIT
1	1	Case		43	1	Bearing Retainer	
2	1	Inlet Head		46	1	Inboard Cover	XX
4	8	Cap Screws		47	2	Bearing Retainer Hex Bolts	
6	1	Pin Stop		48	1	Seal Seat Adapter	
7	1	Fastener Seal	X	49	1	Ball Bearing	X
9	1	Inlet O-ring	X	63	1	Power Rotor	XX
21	2	Suction Idlers	XX	67	2	Pipe Plug	
23	2	Cups	XX	68	1	Tube Fitting	
24	1	Discharge Housing	XX	70	1	Tubing Fitting	
25	1	Mechanical Seal	X	71	1	Seal Pipe	
26	3	Housing Tube		73	3	Inlet Housing	XX
27	8	Thrust Tube O-Rings	X	83	1	Seal O-Ring	X
28	2	Housing / Cover O-Ring	X	86	1	Balance Piston Bushing	XX
29	1	Thrust Plate	XX	87	2	Discharge Idlers	XX
31	1	Key		89	1	Housing Spacer	
35	4	Idlers	XX	100	1	Oil Balance Tube	
42	2	Bearing Snap Rings	X	101	2	Thrust Plate Spacer	
				102	2	Thrust Plate Hex Bolt	

X = Minor Repair Kit Items.
 XX = Major Repair Kit Items. (Items marked (X) are included in Major Repair Kit.)

H. PUMP MAINTENANCE



WARNING

Failure to observe precautions while installing, inspecting and maintaining pump can cause injury to personnel from accidental handling of liquids that may harm skin or clothing, or fire hazard risks from flammable liquids, or injury from high pressure fluid jets.



DANGER

BEFORE working on equipment, make sure all power to equipment is disconnected and locked-out.

H.1 GENERAL COMMENTS

NOTE: Part number identifiers (IDP) contained within parenthesis, such as (9), refer to circled numbers shown on assembly drawing.

De-energize driver before starting with any maintenance action.

H.2 TOOLS REQUIRED

Procedures described in this manual require common mechanics hand tools, a torque wrench, dial indicators for alignment and a suitable lifting device such as slings, straps, etc.

H.3 Pump Disassembly Procedure – See assembly drawing on page 11



CAUTION

Fluid leakage from disassembly of pump may make floor slippery and cause personal injury

Note: To service mechanical seal and ball bearing only, perform H.3, steps 1 thru 5 and H.4, Steps 9 through 12.

1. Close suction and discharge valves. Remove drain plugs (67). Remove seal tubing (71). Remove pump from driver, coupling and base plate. Remove coupling hub and key (31).
2. Remove bearing retainer (43) from inboard cover (46) by removing bolts (47).
3. Remove assembled power rotor (63) from inboard cover (46). Removal of power rotor (63) includes removal of snap rings (42), ball bearing (49), seal (25), seal seat adapter (48) and spacer (38) where applicable.
4. Disassemble power rotor (63) as follows (See Figure 1 for seal drawings) :
 - a. Using a flat nosed tool, such as a screw driver, remove both snap rings (42) from grooves in power rotor (63). Sealed ball bearing (49) is assembled to power rotor (63) with light press fit. Ball bearing (49) may be removed by using bearing puller or vertical arbor press. When using press, place two pieces of key stock through openings of mechanical seal seat adapter (48) underneath ball bearing (49) on both sides of power rotor shaft. Key stock should be long enough to support power rotor (63) as it is placed in press. Position press ram against power rotor (63) coupling end face. Gently press power rotor (63) through ball bearing (49).

CAUTION

ATTENTION

Ensure power rotor (63) does not fall to floor once ball bearing (49) is off of its diameter

- b. Remove seal seat adapter (48) with stationary seal seat. Remove stationary seat with O-ring from seal seat adapter (48). Discard O-ring.
 - c. Loosen set screws and remove rotating seal seat.
5. Remove O-ring (83) from inboard end cover (46).
 6. Remove inboard cover (46) by removing bolts (4). Remove O-ring (28) from inboard cover (46).
 7. Remove inlet head (2) from case (1) by removing bolts (4). Remove and discard O-ring (9) from inlet head (2).
 8. Remove thrust plate (29) and spacers (101) by removing bolts (102).
 9. Remove seal return tube (100) with O-rings (27). Remove and discard O-rings (27).
 10. Remove cups (23) from idlers (21) and idlers (21, 35 and 87) from housings (73, 24).

CAUTION	ATTENTION
Do not permit idlers (21, 35 and 87) to drop as they emerge from housings (73, 24).	

11. Remove spacer (89) from case.
12. Remove pin stop (6) with fastener seal (7) from case (1).
13. Remove housings (73, 24) by pushing them out through discharge end of case (1). Remove and discard housing O-ring (28). Remove tubes (26) and O-rings (27) from housings (24, 73).

CAUTION	ATTENTION
Do not permit housings (73, 24) to drop as they are removed from pump.	

H4. Pump Reassembly Procedure:

Note: Prior to reassembly, all parts should be cleaned and inspected for nicks and burrs. Replace all worn and damaged parts. Imo pump recommends replacement of ball bearing (49), mechanical seal (25), and O-rings (9, 28 and 83) when these parts are disturbed from their original installed position. Parts should be coated with light lubricating oil to assist in assembly.

1. Install O-ring (28) in groove in discharge housing (24). Install O-rings (27) in grooves in all tubes (26 and 100) and install tube (26) in discharge housing (24) on opposite side that O-ring groove is in its OD (28).
2. Install discharge housing (24), O-ring end first, in pump case (1) from suction end until stop pin (6) slot is properly aligned. Install stop pin (6) with fastener seal (7) in case (1).
3. Install housing (73) in pump case (1) with the end that has the two drilled and tapped holes facing the inlet end of the pump. Be sure that tube (26) in housing (24) mates to hole in housing (73).
4. Install the tubes (26) with installed O-rings (27) into next two housings (73) and then housings (73) in case (1). Be sure that tubes (26) in housing (73) mates to holes in other housings(73).

5. Install spacer (89) in case (1).
6. Remove balance piston bushing (86) from inboard cover (46) by heating it to loosen loctite. Be sure to remove all traces of old loctite before installing new bushing
7. Clean and dry inboard cover (46) and balance piston bushing (86) mating surfaces with solvent. Wipe Loctite "T747" Primer or equivalent onto the mating surfaces of bushing (86) and inboard cover (46). Allow 1 to 5 minutes until primer is visibly dry. Apply Loctite 609 or equivalent to bushing (86) and inboard cover (46) mating surfaces. Assemble bushing (86) into inboard cover (46). Allow 10 minutes to dry before proceeding with assembly.
8. Install O-ring (28) on inboard cover. Install inboard cover (46) in case (1) using bolts (4). Ensure seal vent (70) is facing up. Torque bolts (4) to value on assembly drawing.
9. Assemble power rotor (63) and mechanical seal (25) as follows (See Figure 1 for seal drawings):
 - a. Coat O-ring inside of rotating seat with system fluid and slide mechanical seal rotating assembly on power rotor (63) until it seats against the shoulder of seal spacer (38). Tighten rotating seat set screws. Wipe seal face with isopropyl alcohol and a lint free rag.
 - b. Install O-ring in groove of mechanical seal stationary seat. Install seat including O-ring in seal seat adapter (48) ensuring that groove in back of stationary seat mates to spring pin in seal seat adapter (48). Clean seal face with isopropyl alcohol and lint free rag. Put small amount of clean system fluid or light oil on seal running face. Install stationary seat running face against rotating seat face.
 - c. Install inner snap ring (42) in groove of power rotor (63).
 - d. Press bearing (49) on power rotor (63), pressing only on inner race of bearing (49) using an installation sleeve until it is located next to inner snap ring (42).
 - e. Install outer snap ring (42) in groove of power rotor (63)
10. Install O-ring (83) in seal bore of inboard cover (46).
11. Install assembled power rotor (63) in pump, centering all parts as they enter inboard cover (46). Align one of openings in spacer (48) over drain in inboard cover (46).
12. Install bearing retainer (43) on inboard cover (46) using bolts (47). Torque bolts (47) to value on assembly drawing.
13. Install idlers (87, 35 and then 21) into housings (24, 73) by meshing threads with power rotor thread
14. Install cups (23) on idlers (21).
15. Install tube (100) with O-rings (27) installed into inlet housing (73).
16. Install bolts (102) in thrust plate (29) and spacers (101) on bolts (102).
17. Install thrust plate assembly including thrust plate (29), bolts (102) and spacers (101) on housing (73). Be sure idler balance hole in thrust plate (29) mates with tube (100). Torque bolts (102) to value on assembly drawing.

18. Install O-ring (9) on inlet head (2), and install inlet head (2) on case (1) using hex bolts (4). Torque bolts (4) to value on assembly drawing.
19. Install seal pipe (71) and drain plug (67)
20. **NOTE:** Inlet head (2) can be rotated and repositioned in 90 degree increments to suit suction piping. To change inlet position remove bolts (4) and rotate inlet head to desired position. Torque bolts (4) to value on assembly drawing.
21. Install coupling hub key (16). Install and align pump and driver as specified in Installation, Maintenance and troubleshooting Manual, SRM00046.

Metal Bellows Seal

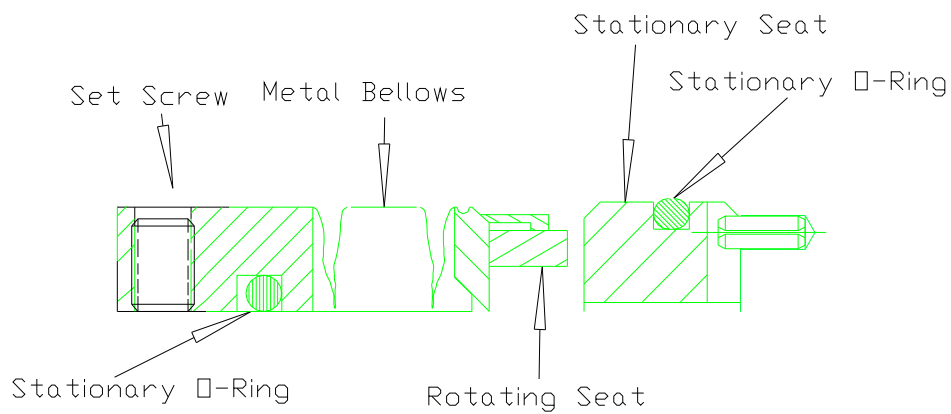

FIGURE 2 – Seal Drawing

I. TROUBLESHOOTING

For assistance with troubleshooting see the Installation, Maintenance and troubleshooting Manual, SRM00046.

J. FIELD AND FACTORY SERVICE AND PARTS

Imo Pump maintains a staff of trained service personnel that can provide pump installation, pump start-up, maintenance/overhaul and troubleshooting supervision as well as installation and maintenance training.

Our factories provide maintenance as well as overhaul and test facilities the in event user prefers to return pumps for inspection or overhaul. Factory-overhauled pumps are normally tested and warranted “as-new” for a period of one year from date of shipment. For either field service or factory overhaul assistance, contact your local Imo Sales Office or representative at Technical/ Customer Service Department in Monroe, NC, USA.

Most pumps have repair kits available. Minor Repair Kits are used to repair leaking seals, bad bearings and/or for re-assembly after pump tear-down. They include (as applicable) pump shaft seals, packing, all gaskets/O-rings and bearings. Major Repair Kits are sufficient to rebuild completely worn-out pumps to “as-new” condition. They include all parts found in Minor Repair Kits plus all major internal parts subject to wear. Since kits have all necessary parts, kit purchase is preferred rather than selecting individual parts. When parts are individually selected from Parts List, some needed components are often overlooked. In addition, mixing worn or used parts with new parts risks rapid wear and shortened service life from new parts.

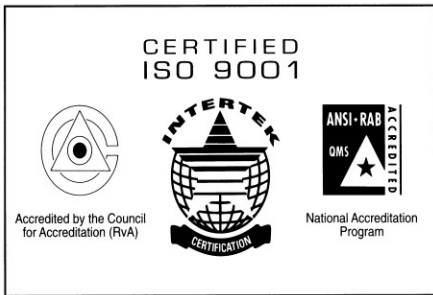

CIRCOR

1710 Airport Road
PO Box 5020
Monroe, NC USA
28111.5020

Tel: +1. 877.853.7867

Email: cc@circor.com

Web: www.circorpt.com

