



PRODUCT SERVICE MANUAL
FOR
CIG Mechanical Seal
Triple Pumps



WARNING

The Imo General Installation Operation, Maintenance, and Troubleshooting Manual, (No. SRM00046), as well as all other component manuals supplied with these type units should be read thoroughly prior to pump installation, start-up, operation, maintenance or troubleshooting.

SRM00052

REV. 04 (20-0051)

February 2020



READ THIS ENTIRE PAGE BEFORE PROCEEDING

FOR THE SAFETY OF PERSONNEL AND TO PREVENT DAMAGE TO THE EQUIPMENT, THE FOLLOWING NOMENCLATURE HAS BEEN USED IN THIS MANUAL:

	DANGER
Failure to observe the precautions noted in this box can result in severe bodily injury or loss of life.	

	WARNING
Failure to observe the precautions noted in this box can cause injury to personnel by accidental contact with the equipment or liquids. Protection should be provided by the user to prevent accidental contact.	

CAUTION	ATTENTION
Failure to observe the precautions noted in this box can cause damage or failure of the equipment.	

Non-compliance of safety instructions identified by the following symbol could affect safety for persons: <div style="text-align: center;"></div>	Safety instructions where electrical safety is involved are identified by: <div style="text-align: center;"></div>	Safety instructions which shall be considered for reasons of safe operation of the pump and/or protection of the pump itself are marked by the sign: <div style="text-align: center;">ATTENTION</div>
--	---	---

CONTENTS

SAFETY AND TABLE OF CONTENTS	A
A. GENERAL INSTRUCTIONS	2
B. INTRODUCTION	2
C. DESCRIPTION OF EQUIPMENT	2
D. PUMP MODEL IDENTIFICATION	2
E. ORDERING INSTRUCTIONS	2
F. OPERATION	3
G. PUMP DISASSEMBLY PROCEDURES	4-6
H. INSPECTION OF PARTS	6-7
I. MACHINING INSTRUCTIONS	7-8
J. SPARE PARTS AND KITS	8
K. PUMP REASSEMBLY PROCEDURES	9-12
L. TROUBLESHOOTING	13
M. ASSEMBLY DRAWING	14

ATTENTION
<p>If operation of this pump is critical to your business, we strongly recommend you keep a spare pump or major repair kit in stock at all times. As a minimum, a minor repair kit (O-rings, gaskets, shaft seal and bearings) should be kept in stock so pump refurbishment after internal inspection can be accomplished.</p>

A. GENERAL INSTRUCTIONS

The instructions found herein cover the disassembly, assembly and parts identification of CIG triple pumps.

NOTE: Individual contracts may have specific provisions that vary from this manual. Should any questions arise which may not be answered by these instructions, refer to the General Installation Operation, Maintenance, and Troubleshooting Manual, (No. SRM00046), provided with your order. For further detailed information and technical assistance please refer to Imo Pump, Technical/Customer Service Department, at (704) 289-6511.

This manual cannot possibly cover every situation connected with the installation, operation, inspection, and maintenance of the equipment supplied. Every effort was made to prepare the text of the manual so that engineering and design data is transformed into the most understandable wording. Imo Pump must assume the personnel assigned to operate and maintain the supplied equipment and apply this instruction manual have sufficient technical knowledge and are experienced to apply sound safety and operational practices which may not be otherwise covered by this manual.

In applications where equipment furnished by Imo Pump is to become part of processing machinery, these instructions should be thoroughly reviewed to ensure proper fit of said equipment into overall plant operational procedures.



WARNING

If installation, operation, and maintenance instructions are not correctly and strictly followed and observed, injury to personnel or serious damage to pump could result. Imo Pump cannot accept responsibility for unsatisfactory performance or damage resulting from failure to comply with instructions.

B. INTRODUCTION

This instruction manual covers CIG triple pumps. This series of pumps has been designed for use in hydraulic, lubricating seal and fuel oil applications. The model and design construction of each pump can be identified by the designator code on the pump nameplate. Definitions of model designators are identified in Figure 1.

C. DESCRIPTION OF EQUIPMENT

The CIG triple pumps are positive displacement, internal gear pumps consisting of a single shaft that runs through the center of pump housings. This shaft drives the external gears (pinion gears) which in turn drives the internal gears (ring gears). Fluid is carried between the internal and external gear teeth of each pump and is discharged as the teeth mesh. The pinion and ring gears are separated in each pump by a crescent which is a sealing element in the pump between inlet and discharge ports.

D. PUMP MODEL IDENTIFICATION

This instruction manual covers the Imo CIG triple series pumps.

The model of each pump is identified on the pump nameplate. Refer to Figure 1 for instructional keys when using this manual.

E. ORDERING INSTRUCTIONS

When corresponding with Imo Pump regarding CIG Single Series pumps, refer to the pump nameplate, this instruction manual, and the assembly drawing as instructed below:

1. From pump nameplate, record the pump model number. Also record the manufactured lot number and date (these are stamped on the housing near the nameplate).
2. Record instruction manual number, revision and date.
3. From the instruction manual, record the figure numbers that apply to the replacement part(s)

4. From the assembly drawing or instruction manual (see Table 1, Pump Parts List) provide the IDP number(s) and names for the replacement part(s).
5. Give the above information to your Imo service representative.

Imo sales and service representatives are listed herein and in General Installation Operation, Maintenance, and Troubleshooting Manual, (No. SRM00046).

F. OPERATION

LIQUID LIMITATIONS

Never operate with fluids that are corrosive to iron, steel, aluminum or bronze. The pump is designed for fluids having the general characteristics of oil.

CAUTION	ATTENTION
<p>Operating conditions, such as speed, fluid viscosity, temperature, inlet pressure, discharge pressure, filtration, duty cycle, drive type, mounting, etc. are interrelated. Due to these variable conditions, the specific application limits may be different from that of the operational limitations. This equipment must not be operated without verification that operating requirements are within its capabilities.</p>	

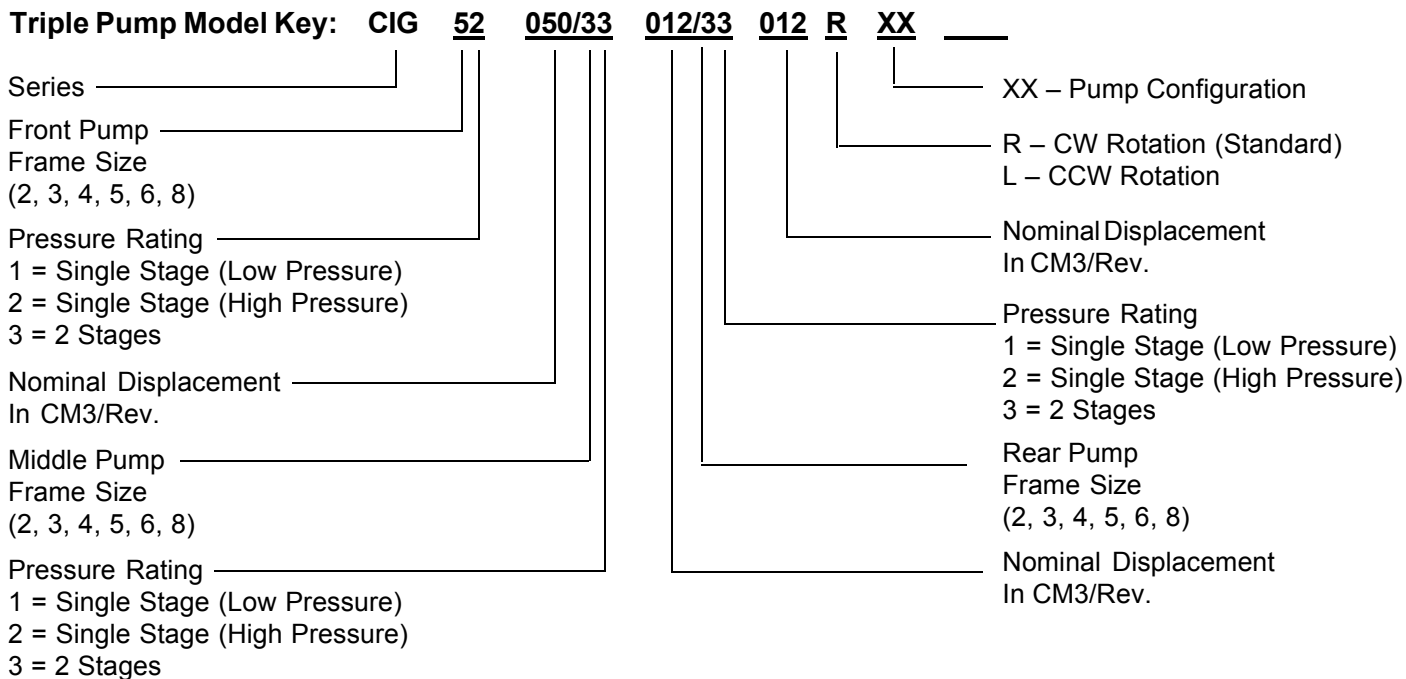

Figure 1 – Triple Pump Configurations

G. PUMP DISASSEMBLY

Refer to Assembly Drawing In Back Of Manual

CAUTION	ATTENTION
Read this entire procedure <u>before</u> disassembling pump.	

1. Remove drive key (36).
2. Remove capscrews (42) and end cover (15) with O-ring (67).
3. Remove capscrews (17).
4. Remove back cover (63) from shaft (6). Do not permit dowel pin (22) to drop as back cover (63) is removed. Remove dowel pin (60) from either back cover (63) or square housing (62), whichever is applicable. Remove and discard O-ring (84)

NOTE: If back cover (63) will not slide easily off shaft (6), clamp housing (62) in a vise with back cover (63) free. With a soft-headed hammer, tap alternately on ears of back cover (63) until there is sufficient gap to insert a wedging device between back cover (63) and housing (62). Pry gap until back cover (63) is free to slide off shaft (6).

CAUTION	ATTENTION
Take care not to damage either faces that are being pried against or O-ring (84) with prying device.	

CAUTION	ATTENTION
If back cover (63) did not slide off easily because its bushing (54) was seized on shaft (6), ball bearing (31) was most likely damaged when cover was pried off, and must be replaced. If back cover (63) did not slide off easily because it was stuck on counterbore of square housing (62), ball bearing (31) may not have to be replaced.	

NOTE: If back cover (63) cannot be removed without applying excessive force, unit should be returned to Imo for further disassembly and inspection.

CAUTION	ATTENTION
In next step, ring gear (65), pinion (64) and key (66) will be removed. If ring (65) and pinion (64) are to be reused, identify them, with a marker or the like, so it can be determined to which housing they belong (if there is more than one housing in pump) and which direction face of each gear was positioned in housing. Do not mark with scribe or punch as this may leave a burr or high spot which could lead to pump damage or seizure. If key (66) is to be reused, mark it so that it can be assembled into its original stage and facing its original direction.	

5. Remove pinion gear (64) and key (66) from shaft (6) and ring gear (65) from square housing (62).

CAUTION	ATTENTION
If pinion gear (64) will not slide easily off shaft (6), its key (66) is most likely at least partially sheared. In this case the disassembly cannot be completed in the field without the chance of damaging other good parts and the unit should be returned to Imo for further disassembly and inspection.	

NOTE: If ring gear (65) will not come out of housing (62), it is most likely seized on its OD and will not be possible to remove. The pump can still be disassembled with the ring gear (65) left in the housing (62).

6. Remove square housing (62) from shaft (6). Do not permit dowel pin (22) to drop as housing (62) is removed. Remove dowel pin (22) from either housing (62) or (7), whichever is applicable.

NOTE: If square gear housing (62) will not slide easily off shaft (6), clamp housing (7) in a vise with housing (62) free. Insert Prying device between the two housings and pry gap until housing (62) is free to slide off shaft (6). Remove and discard O-ring (40), if it did not come off with square housing (62).

CAUTION	ATTENTION
Take care not to damage either faces that are being pried against or O-ring (10) with prying device.	
CAUTION	ATTENTION
If gear housing (62) did not slide off easily because its bushing (82) was seized on shaft (6), ball bearing (31) was most likely damaged when housing (62) was pried off, and must be replaced. If housing (62) did not slide off easily because it was stuck in housing tube (23), ball bearing (31) may not have to be replaced.	

NOTE: If square housing (62) cannot be removed without applying excessive force, unit should be returned to lmo for further disassembly and inspection.

7. Remove housing tube (23) if it was damaged and needs to be replaced.

CAUTION	ATTENTION
In next step, ring gear (20), pinion (19) and key (21) will be removed. If ring (20) and pinion (19) are to be reused, identify them, with a marker or the like, so it can be determined to which housing they belong (if there is more than one housing in pump) and which direction face of each gear was positioned in housing. Do not mark with scribe or punch as this may leave a burr or high spot which could lead to pump damage or seizure. If key (21) is to be reused, mark it so that it can be assembled into its original stage and facing its original direction.	

8. Remove capscrews (39).

9. Remove square gear housing (7), ring gear (20), pinion gear (19) and key (21) from shaft (6). Do not permit dowel pin (37) to drop as housing (7) is removed. Remove dowel pin (37) from either housing (7) or intermediate flange (5), whichever is applicable.

CAUTION	ATTENTION
If square gear housing (7) will not slide easily off shaft (6), clamp intermediate flange (5) in a vise with square of housing free (7). Insert prying device between intermediate flange (5) and square housing (7). Pry gap until square housing (7) is free to slide off shaft	

CAUTION	ATTENTION
Take care not to damage either faces that are being pried against or O-ring (10) with prying device.	

CAUTION	ATTENTION
If gear housing (7) did not slide off easily because its bushing (53) was seized on shaft (6), ball bearing (31) was most likely damaged when housing (7) was pried off, and must be replaced. If housing (7) did not slide off easily because it was stuck in intermediate cover (5) counter-bore, ball bearing (31) may not have to be replaced.	

NOTE: If housing, ring gear or pinion gear cannot be removed without applying excessive force, unit should be returned to lmo for further disassembly and inspection.

10. Remove O-ring (41) from intermediate flange (5) if it did not come off with last housing removed.

11. Remove intermediate flange (5) from shaft (6). Do not permit dowel pin (37) to drop as intermediate flange (5) is removed. Remove dowel pin (37) from square of housing (4) or intermediate flange (5) whichever is applicable.

NOTE: If intermediate flange (5) will not slide easily off shaft (6), clamp square housing (4) in a vise with intermediate flange (5) free. Insert prying device between intermediate flange (5) and square housing (4). Pry gap until intermediate flange (5) is free to slide off shaft.

CAUTION	ATTENTION
Take care not to damage either faces that are being pried against or O-ring (41) with prying device.	

CAUTION	ATTENTION
If intermediate flange (5) will not slide off easily because its sleeve bushing (53) was seized on shaft (6), ball bearing (31) was most likely damaged and must be replaced. If intermediate flange (5) did not slide off easily because it was stuck on housing (4) rabbitt, ball bearing (31) may not have to be replaced.	

12. Remove O-ring (41).

CAUTION	ATTENTION
In next step, ring gear (12), pinion (11) and key (13) will be removed. If ring (12) and pinion (11) are to be reused, identify them, with a marker or the like, so it can be determined to which housing they belong (if there is more than one housing in pump) and which direction face of each gear was positioned in housing. Do not mark with scribe or punch as this may leave a burr or high spot which could lead to pump damage or seizure. If key (13) is to be reused, mark it so that it can be assembled into its original stage and facing its original direction.	

13. Remove pinion gear (11) and key (13) from shaft (6) and ring gear (12) from front pump square housing (4).

CAUTION	ATTENTION
If pinion gear (11) will not slide easily off shaft (6), its key (13) is most likely at least partially sheared. In this case, the disassembly cannot be completed in the field without the chance of damaging other good parts, and the unit should be returned to Imo for further disassembly and inspection.	

NOTE: If ring gear (12) will not come out of housing (4), it is most likely seized on its OD and will not be possible to remove. The pump can still be disassembled with the ring gear (12) left in housing (4).

14. Remove square housing (4) from shaft (6). Do not permit dowel pin (37) to drop as square housing (4) is removed. Remove dowel pin (37) from either square housing (4) or front flange (2), whichever is applicable. Remove O-ring (40).

NOTE: If square gear housing (4) will not slide easily off shaft (6), clamp it in a vice with the front flange (2) free. With a soft-headed hammer, tap on gear end of shaft (6) until there is sufficient gap to insert a wedging device between the square housing (4) and the front flange (2). Pry the gap until square housing (4) is free to slide off shaft (6).

CAUTION	ATTENTION
Take care not to damage either faces that are being pried against or O-ring (10) with prying device.	

CAUTION	ATTENTION
If the shaft had to be hammered to remove the square gear housing (4), the ball bearing (31) was damaged and must be replaced.	

NOTE: If square housing (4) cannot be removed without applying excessive force, unit should be returned to Imo for further disassembly and inspection.

15. Remove capscrews (42) from seal housing (9).

16. Remove shaft (6) from front flange (2). Removal of shaft also removes seal housing (9), outside lip seals (32), ball bearing (31), and bearing retaining ring (33).

17. Remove seal housing (9), with lip seals (32), from shaft (6).
18. If lip seals (32) are to be replaced, remove and discard them from seal housing (9)..
19. If ball bearing (31) is to be replaced, remove snap ring (33) from shaft (6), press ball bearing (31) off shaft (6) and discard.
20. If inside lip seal (51) is to be replaced remove and discard lip seal (51).

H. INSPECTION OF PARTS

1. BALL BEARING – Ball bearings should be free turning and quiet. Their grease should have a soft consistency and not look or smell burned.
2. GEAR FACES – Some light scratching is acceptable, but if there is any scoring, the part should be replaced. These faces cannot be ground to remove a heavy score mark because their width is critical to performance of pump. Grinding more than several ten thousandths of an inch will cause low capacity. If the face is not flat, pump seizure could occur.

NOTE: Rework other than light stoning or cleaning of gears or gear housings is not recommended. New gear housings are provided with sleeve bearing factory installed.

3. RING GEAR OD – Light scratching and polishing is acceptable. If scoring is present, ring gear should be replaced.
4. HOUSING
 - a. Faces – Some light scratching is acceptable, but if there is any scoring, the part should be replaced.
 - b. Crescent – This piece should be checked for gouges or scoring. If the marking is severe, housing should be replaced.
 - c. ID – If any scoring is present, housing should be replaced.
5. SHAFT – Check shaft for wear, particularly areas where lip seals and bushings are located when pump is assembled. Any heavy wear is cause for shaft replacement. Check edges of keyways for cracks, chipping or rounding. If any of these exists, shaft should be replaced.
6. SLEEVE BEARING – If scoring or heavy polishing is present, bearing must be pressed out of housing, replaced and sized (see machining instructions on next page).
7. FRONT AND INTERMEDIATE COVERS – If faces are scored or heavily scratched, they must be machined per machining instructions. Check ball bearing seating area in front cover after severe ball bearing failure. If ball bearing seating OD is badly scored, deburr it before pump assembly.

I. MACHINING INSTRUCTIONS

The front cover (2) and intermediate cover (5) can usually be restored to as-new condition by machining damaged faces. Sleeve bushings (53), (54) usually require replacement when cover is machined.

To repair damage to face of front cover and intermediate cover (Figure 2) and to replace sleeve bushings (C) proceed as follows:

1. Press out sleeve bushing (53), (54) from front of intermediate cover.

NOTE: If pump is equipped with bronze bearing, consult factory.

2. Place front cover or intermediate cover in a lathe and indicate face (A) and counterbore (B) square and concentric with respect to bore (C) within .0008 inch TIR.

- Machine face (A) deep enough to remove any scored material. Ensure that face is flat within .0008 inch TIR with a 32 microinch finish.

CAUTION	ATTENTION
Being out of flat in excess of .0008" can cause pump failure.	

NOTE: If more than .015" is machined (removed) from face (A, Figure 2), the same amount should be machined (removed) from G and F, Figure 2.

- Press sleeve bushing (53) (54) in front cover or intermediate cover ensuring that split in bushing (53) (54) is positioned as shown in Figure 2.
- Fabricate a bushing sizing tool as shown in Figure 3. Press sizing tool through bushing from same direction bushing was originally installed to properly size bushing bore.

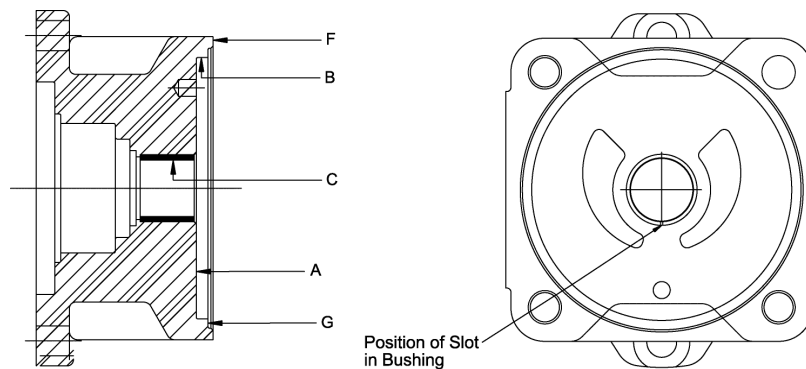
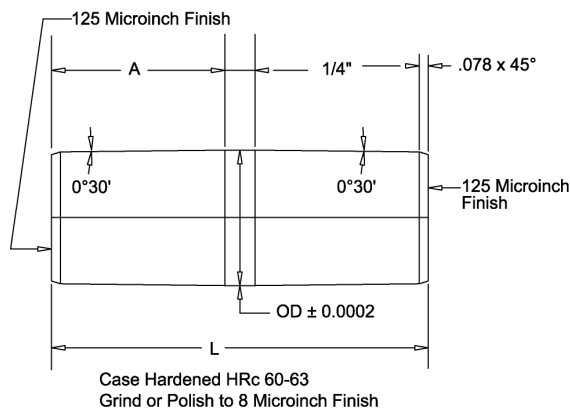

Figure 2 – Front Cover



Frame Size	"L"	"A"	"OD"
	in.	in.	in.
2	2.284	0.984	0.712
3	2.677	1.181	0.87
4	3.071	1.378	1.1062
5	3.465	1.575	1.382
6	4.252	1.969	1.776
8	5.039	2.362	2.17

Figure 3 – Sleeve Bearing (53), (54), (82) Sizing Tool

J. SPARE PARTS AND KITS

IDP	QTY	DESCRIPTION	Seal Kit	Shaft Kit	Front Pump Square Hsg. & Gear Set Kit*	Middle Pump Square Hsg. & Gear Set Kit*	Rear Pump Square Hsg. & Gear Set Kit
2	1	Front Flange					
4	1	Front Pump Square Housing.			X		
5	1	Intermediate Cover					
6	1	Shaft		X			
7	1	Middle Pump Square Housing				X	
9	1	Seal Housing					
10	1	Housing Tube O-Ring	X				
11	1	Front Cover Pinion Gear			X		
12	1	Front Pump Ring Gear			X		
13	1	Front Pump Key		X			
15	1	Rear Cover					
17	1	Rear Pump Tie Rod					
19	1	Middle Pump Pinion Gear				X	
20	1	Middle Pump Ring Gear				X	
21	1	Middle Pump Key		X			
22	1	Middle Pump Pin					
23	1	Housing Tube					
24	1	Rear Pump Pin					
31	1	Ball Bearing		X			
32	1	Front Lip Seals	X				
33	1	Ball Bearing Snap Ring		X			
36	1	Shaft Key		X			
37	1	Front Housing Pin					
38	2	Rear Cover Capscrews					
39	4	Front Pump Tie Rods					
40	1	Seal Cover O-Ring	X				
41	1	Front Housing O-Ring	X				
42	2	Seal Cover Capscrew					
51	1	Inside Lip Seal	X				
53	2	Front Pump Bushings			X		
54	2	Middle Pump Bushings				X	
60	1	Middle Pump Pin					
62	1	Rear Pump Housing					X
63	1	Rear Flange					
64	1	Rear Pump Pinion					X
65	1	Rear Pump Ring					X
66	1	Rear Pump Key		X			
67	1	Rear Cover O-Ring	X				
82	2	Rear Pump Bushings					X
84	1	Rear Pump O-Ring	X				

*Housings, Pinions and Rings Cannot Be Sold Separately Since They Are Matched Sets

Table 1 – Pump Parts List

K. REASSEMBLY OF PUMP

CAUTION	ATTENTION
READ THIS ENTIRE PROCEDURE <u>BEFORE</u> ASSEMBLING PUMP.	

NOTE: Inspect all running surfaces for scratching, scoring and wear prior to assembly of pump. Minor scratching is acceptable. If parts are heavily scratched or scored, they should be replaced. Thoroughly clean all pump components.

	WARNING
Follow the supplier's recommendations when using cleaning fluids.	

NOTE: Imo Pump recommends replacement of all O-rings, lip seals, and ball bearing every time these parts are disturbed from their original installed position. If O-rings and lip seals are, in general, not to be replaced, they must be thoroughly inspected for nicks, cuts or other damage. If any individual O-ring or lip seal is damaged, it must be replaced.

CAUTION	ATTENTION
If ball bearing (031) is removed from shaft (006), it <u>must</u> be replaced. Lip seals (032) <u>must</u> also be replaced if they are removed.	

NOTE: Refer to "Inspection of Parts" for additional information on part inspection and replacement. Wipe all parts with light lubricating oil to assist in assembly.

CAUTION	ATTENTION
Prior to assembly, remove all nicks and sharp edges on housings and gears with deburring stone. Particular attention should be paid to kidney port chamfers in housings, to faces of ring and pinion gears and to areas of housings that were pried apart on disassembly. Avoid excessive breaking of edges at outside diameter of ring gear as this could negatively affect flow rate. When reinstalling gears in housings, be sure gears are installed in housings from which they were removed and face direction from which they were removed.	

Refer to Assembly Drawing In Back Of Manual

1. Press ball bearing (31) onto shaft (6), pressing only on inner race, until it contacts mating shoulder on shaft (6).

CAUTION	ATTENTION
Pressing bearing (31) on via its outer race will likely damage it, leading to reduced service life or failure.	

2. Install snap ring (33) onto shaft (6).
3. Wipe small amount of grease on edges of lip seals (32) for lubrication.
4. Press lip seals (32), one at a time, into seal housing (9) facing direction shown on assembly.

CAUTION	ATTENTION
Be sure to press only on outside diameter of lip seals (32).	

5. Wipe small amount of grease on edge of inside lip seal (51) and install lip seal (51) in front flange (2). Be sure lip is facing direction shown on assembly drawing.
6. Install shaft (6) assembly which includes ball bearing (31), and snap ring (33) into front flange (2).

7. Install O-ring (40) onto seal housing (9) rabbet.
8. Install seal housing (9) in front flange (2) and secure with cap screws (42). Torque capscrews, with torque wrench, to torque values on assembly drawing.
9. Install dowel pin (37) in front flange (2), if applicable.
10. Install O-ring (40) in face of front flange (2).
11. Install square housing (4) on shaft (6) and slide it up until it engages dowel pin (37) and counterbore in front flange (2) and is tight up against front flange face (2).
12. Install key (13) chamfer side up in keyway of shaft (6) inside square housing (4) and push it up as far as possible toward drive end of pump.

CAUTION	ATTENTION
If key (13) has a step, install key (13) with step facing up and toward square housing (4).	

CAUTION	ATTENTION
When key (13) is installed there must at least an approximately .020" gap between it and housing (4) face. If not, it should be removed and a small step filed in the portion of the key (13) that sticks up above the shaft keyway to prevent the key (13) from touching the housing (4) face.	

13. Install pinion gear (11) on shaft (6). Pinion gear (11) should slide freely on shaft (6) and key (13). If not, ensure key (13) is properly installed and shaft (6) and pinion (11) keyway are free of burrs. Ensure pinion (11) is installed in stage from which it was removed and is facing direction from which it was removed.

CAUTION	ATTENTION
If gears are installed in wrong housing, pump may not perform properly or may seize during operation. This is because gears are matched to each housing individually and may not have correct clearances if installed in another housing. If gears are installed facing wrong direction, pump may not perform properly or may seize during operation. This is because some gears have chamfers on only one side. These chamfers must be positioned facing inside of housing so that there will be no interference with housing radii.	

14. Install ring gear (12) in square gear housing (4). Ensure ring gear (12) is installed in stage from which it was removed and is facing direction from which it was removed.

CAUTION	ATTENTION
If gears are installed in wrong housing, pump may not perform properly or may seize during operation. This is because gears are matched to each housing individually and may not have correct clearances if installed in another housing. If gears are installed facing wrong direction, pump may not perform properly or may seize during operation. This is because some gears have chamfers on only one side. These chamfers must be positioned facing inside of housing so that there will be no interference with housing radii.	

15. Install O-ring (41) on square gear housing (4).
16. Install dowel pin (37) in intermediate flange (5).
17. Install intermediate flange (5) onto shaft (6) and slide it on until its pin (37) engages pin in hole in face of previously installed housing (4) and is tight up against face of previously installed housing (4).

18. Install square housing key (21), chamfer side up, into keyway of shaft (6).

CAUTION	ATTENTION
If key (21) has a step, install key (21) with step facing up and away intermediate cover (5) face.	

CAUTION	ATTENTION
When key (21) is installed there must be an approximately .020" gap between it and intermediate cover (5) face. If not, key (21) should be removed and a small step filed in the portion of the key (21) that sticks up above the shaft keyway to prevent the key (21) from touching the side plate (56) in the intermediate cover (5) face.	

19. Install square housing pinion gear (19) on shaft (6). Pinion gear (19) should slide freely on shaft (6) and key (21).

If not, ensure key (21) is properly installed and shaft (6) and pinion (19) keyway are free of burrs. Ensure pinion (19) is installed in stage from which it was removed and is facing direction from which it was removed.

CAUTION	ATTENTION
If gears are installed in wrong housing, pump may not perform properly or may seize during operation. This is because gears are matched to each housing individually and may not have correct clearances if installed in another housing. If gears are installed facing wrong direction, pump may not perform properly or may seize during operation. This is because some gears have chamfers on only one side. These chamfers must be positioned facing inside of housing so that there will be no interference with housing radii.	

20. Install ring gear (20) in square gear housing (7). Ensure ring gear (20) is installed in housing (7) from which it was removed and is facing direction from which it was removed.

CAUTION	ATTENTION
If gears are installed in wrong housing, pump may not perform properly or may seize during operation. This is because gears are matched to each housing individually and may not have correct clearances if installed in another housing. If gears are installed facing wrong direction, pump may not perform properly or may seize during operation. This is because some gears have chamfers on only one side. These chamfers must be positioned facing inside of housing so that there will be no interference with housing radii.	

21. Install square gear housing (7), with installed ring gear (20), onto shaft (6). Ensure dowel pin (37) engages dowel pin hole in intermediate flange (5) and pinion gear (19) installed on shaft (6) is properly positioned to enter gear housing (7).

22. Install capscrews (39) and tighten with torque wrench to torque values on assembly drawing. Torque one half value for all capscrews first, then torque full specified torque values. Capscrew tightening pattern should be across opposite corners for both half torque and full torque tightening.

NOTE: With capscrews (39) torqued to full value, pump shaft must turn freely by hand and without significant internal snagging. Otherwise, unit has not been properly assembled.

23. Install dowel pin (22) in back of housing (7).

24. Install O-rings (10) on housing tube and housing tube (23) on back of housing (7)

25. Install O-ring (40) on square housing (62). Install square housing (62) on shaft (6) and slide it up until it engages dowel pin (22) and housing tube (23) and is tight up against back of previous housing (7).

26. Install key (66) chamfer side up in keyway of shaft (6) inside square housing (62) and push it up as far as possible toward drive end of pump.

CAUTION	ATTENTION
If key (66) has a step, install key (66) with step facing up and toward drive end of pump.	

CAUTION	ATTENTION
When key (66) is installed there must be an approximately .020" gap between it and housing (62) face. If not, it should be removed and a small step filed in the portion of the key (66) that sticks up above the shaft keyway to prevent the key (66) from touching the housing (62) face.	

27. Install pinion gear (64) on shaft (6). Pinion gear (64) should slide freely on shaft (6) and key (66). If not, ensure key (66) is properly installed and shaft (6) and pinion (64) keyway are free of burrs. Ensure pinion (64) is installed in stage from which it was removed and is facing direction from which it was removed.

CAUTION	ATTENTION
If gears are installed in wrong housing, pump may not perform properly or may seize during operation. This is because gears are matched to each housing individually and may not have correct clearances if installed in another housing. If gears are installed facing wrong direction, pump may not perform properly or may seize during operation. This is because some gears have chamfers on only one side. These chamfers must be positioned facing inside of housing so that there will be no interference with housing radii.	

28. Install ring gear (65) in square gear housing (62). Ensure ring gear (65) is installed in stage from which it was removed and is facing direction from which it was removed if pump has more than one stage.

CAUTION	ATTENTION
If gears are installed in wrong housing, pump may not perform properly or may seize during operation. This is because gears are matched to each housing individually and may not have correct clearances if installed in another housing. If gears are installed facing wrong direction, pump may not perform properly or may seize during operation. This is because some gears have chamfers on only one side. These chamfers must be positioned facing inside of housing so that there will be no interference with housing radii.	

29. Install O-ring (10) on square gear housing (62).
30. Install dowel pin (22) in square gear housing (62).
31. Install back cover (63) on shaft (6). Slide it on until it engages pin (22) in face of housing (62) and is tight up against face of previously installed housing (62).
32. Install capscrews (17) and tighten with torque wrench to torque values on assembly drawing. Torque one half value for all capscrews first, then torque full specified torque values. Capscrew tightening pattern should be across opposite corners for both half torque and full torque tightening.

NOTE: With capscrews (17) torqued to full value, pump shaft must turn freely by hand and without significant internal snagging. Otherwise, unit has not been properly assembled.

33. Install O-ring (67) into rear cover (15). If necessary, use a dab of grease to hold O-ring (067) in place.
34. Install rear cover (15) on back cover (63) using capscrews (38). Tighten capscrews (38) with torque wrench to torque values on assembly drawing.

35. Install coupling key (36) in keyway of shaft (6).

CAUTION

ATTENTION

Take care not to bump shaft during storage, transportation, or installation of pump into operating system.

L. TROUBLESHOOTING

For assistance with troubleshooting, see Imo General Installation Operation, Maintenance, and Troubleshooting Manual, (No. SRM00046).

CAPSCREW 17 & 39 TORQUE TABLE				
FRAME SIZE	BOLT SIZE	PUMP MODIFICATION	TORQUE	
			LB FT	N.m
2	M10	W P	30±2	41
3	M12	W P	60±5	81
4	M16	W P	115±10	156
5	M20	W P	220±15	298
6	M24	W P	435±15	590
8	M30	W P	870±25	1180

NOTES:
 1. POSITION OF PINION KEY
 CRITICAL IN KEYWAY,
 CHAMFERS TO BE IN PINION
 KEYWAY, ROUNDED
 CORNERS TO BE IN SHAFT
 KEYWAY.

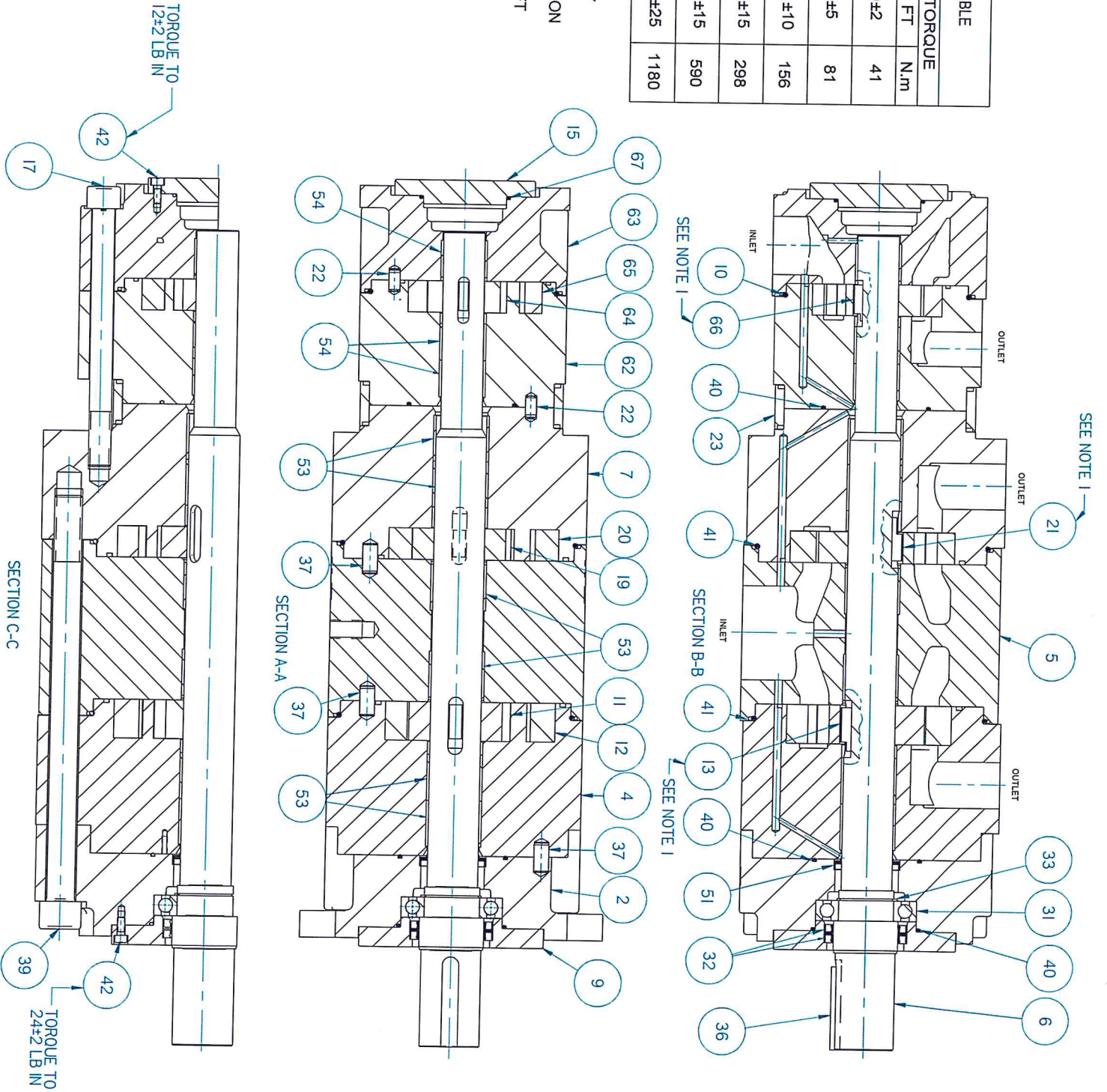

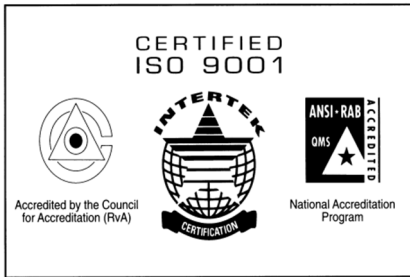

CIRCOR

1710 Airport Road
PO Box 5020
Monroe, NC USA
28111.5020
Tel: +1. 877.853.7867

Email: cc@circor.com

Web: www.circorpt.com