



IMO®

**INSTRUCTION MANUAL  
AND  
PARTS LIST  
FOR  
3E SERIES PUMPS  
ROTOR SIZES 118 AND 118P**



**WARNING**

The Imo General Installation Operation, Maintenance, and Troubleshooting Manual, (No. SRM00046), along with this manual and all other component manuals supplied with these type units should be read thoroughly prior to pump installation, start-up, operation, maintenance or troubleshooting.


**SRM00017**


**Rev. 06 (20-0051)**

**February 2020**



## READ THIS ENTIRE PAGE BEFORE PROCEEDING

FOR SAFETY OF PERSONNEL AND TO PREVENT DAMAGE TO EQUIPMENT, THE FOLLOWING NOMENCLATURE HAS BEEN USED IN THIS MANUAL:

	<b>DANGER</b>	
Failure to observe precautions noted in this box can result in severe bodily injury or loss of life.		

	<b>WARNING</b>	
Failure to observe precautions noted in this box can cause injury to personnel by accidental contact with equipment or liquids. Protection should be provided by user to prevent accidental contact.		

	<b>CAUTION</b>	<b>ATTENTION</b>	
Failure to observe precautions noted in this box can cause damage or failure of equipment.			

Non compliance of safety instructions identified by the following symbol could affect safety for persons:  	Safety instructions where electrical safety is involved are identified by:  	Safety instructions which shall be considered for reasons of safe operation of the pump and/or protection of the pump itself are marked by the sign:  <div style="text-align: center;"><b>ATTENTION</b></div>
--	---	---

### CONTENTS

Safety and Table of Contents .....	2
General Instructions .....	3
Introduction.....	3
Pump Model Identification .....	4
Operating Limits.....	4
Maintenance, Bearing & Seal Installation.....	5-6-7
Disassembly and Assembly Instructions .....	7-8
Spare Parts and Kits.....	8
Ordering Instructions .....	9
Pump Assembly Drawings.....	10-17


<b>ATTENTION</b>
<b><i>If operation of this pump is critical to your business, we strongly recommend you keep a spare pump or major repair kit in stock at all times. As a minimum, a minor repair kit (o-rings, gaskets, shaft seal and bearings) should be kept in stock so pump refurbishment after internal inspection can be accomplished.</i></b>

## GENERAL INSTRUCTIONS

Instructions given herein cover generally operation and maintenance of subject equipment. Should any questions arise which may not be answered specifically by these instructions, they should be referred to Imo Pump for further detailed information and technical assistance.

This manual cannot possibly cover every situation connected with operation, adjustment, inspection, test, overhaul and maintenance of equipment furnished. Every effort is made to prepare text of manual so that engineering and design data is transformed into most easily understood wording. Imo Pump, in furnishing this equipment and this manual, must presume that operating and maintenance personnel assigned thereto have sufficient technical knowledge and experience to apply sound safety and operational practices which may not be otherwise covered herein.

In applications where Imo Pump furnished equipment is to be integrated with a process or other machinery, these instructions should be thoroughly reviewed to determine proper integration of equipment into overall plant operational procedures. On critical or dangerous equipment, provide suitable safety and emergency systems to protect personnel and property from injury due to pump malfunction. If pump handles flammable, toxic, corrosive or explosive fluids, provide for safety in event of pump leakage or malfunction.

	<b>WARNING</b>
<p>If installation, operation and maintenance instructions are not correctly and strictly followed and observed, injury to personnel or serious damage to pump could result. Imo Pump cannot accept responsibility for unsatisfactory performance or damage resulting from failure to comply with instructions.</p>	

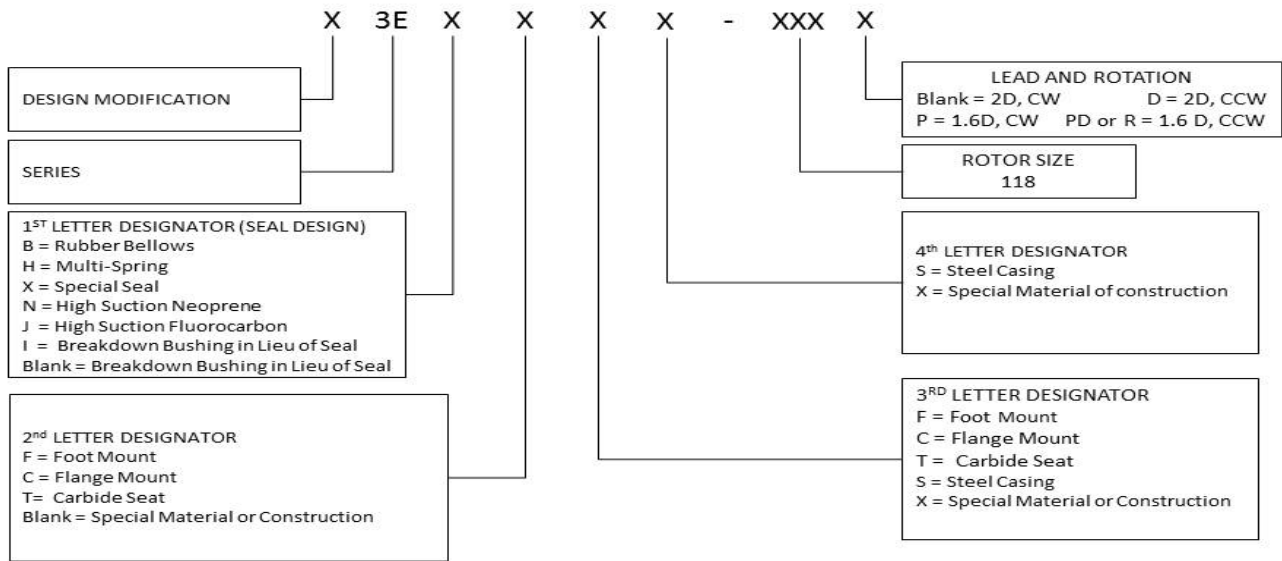
## INTRODUCTION

Instruction manual covers 3E-118 and 118P Series pumps. Specific models covered by this manual are identified in Table 1. Model of each particular pump is identified on pump end cover. Refer to Figure 1 for definition of model designator. Refer to assembly drawing corresponding to your pump model, Figures 2 and 3, Figures 5 through 8, and Figures 11 through 14 as you use this instruction manual.

**Table 1 – 3E Series Pump Models**

<b>ROTOR SIZES - 118 AND 118P</b>					
<b>PUMP MODEL<sup>(1)</sup></b>	<b>FIGURE NO.</b>	<b>PUMP MODEL<sup>(1)</sup></b>	<b>FIGURE NO.</b>	<b>PUMP MODEL<sup>(1)</sup></b>	<b>FIGURE NO.</b>
C3EBC	5	D3EBCS	6	D3EXCS	12
C3EBCX	5	D3EBTCS	6	D3EBJC	14
C3EBF	7	D3EBFS	8	D3EIC	11
C3EHC	5	D3EBTFS	8	E3EBC	5
C3EHF	7	D3EHCS	6		
C3EIC	11	D3EHCST	6		
C3EX	13	D3EHFS	8		
C3ENC	14	D3EICS	12		

**Figure 1 – Definition of Model Designators of 3E Series Pumps**



**Figure 1 – Definition of Model Designators of 3E Series Pumps**

**OPERATING LIMITS**

<b>CAUTION</b>	<b>ATTENTION</b>
<p>Operating conditions, such as speed, fluid viscosity, temperature inlet pressure, discharge pressure, filtration, duty cycle, drive type, mounting, etc., are interrelated. Due to these variable conditions, specific application limits may be different from operational limitations. Equipment must not be operated without verifying system’s operating requirements are within pump’s capabilities.</p>	

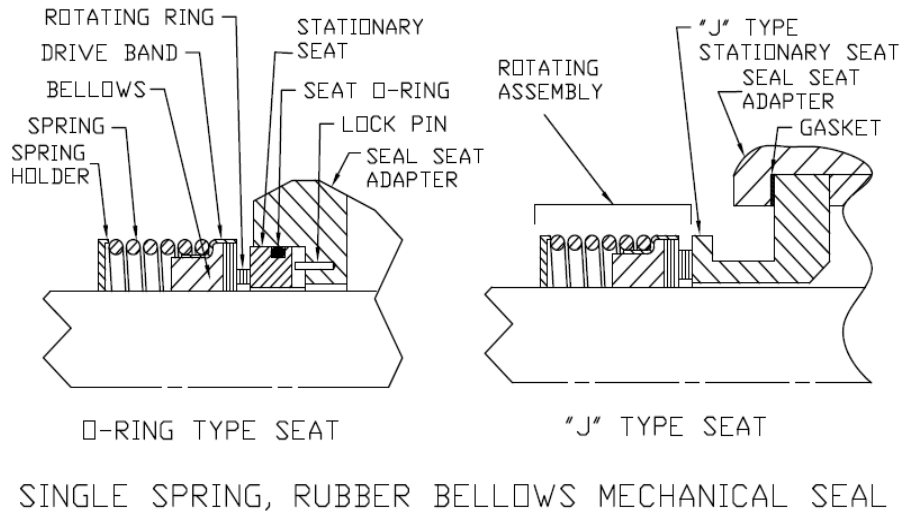
**Pump Weights:** C-Face and Integral Mount for both 118 and 118P sizes = 9 LBS [4 kg]  
 Foot Mount = 10.2 LBS [5 kg]

**Pump Airborne Noise levels are expected to be less than 70 dBA.**

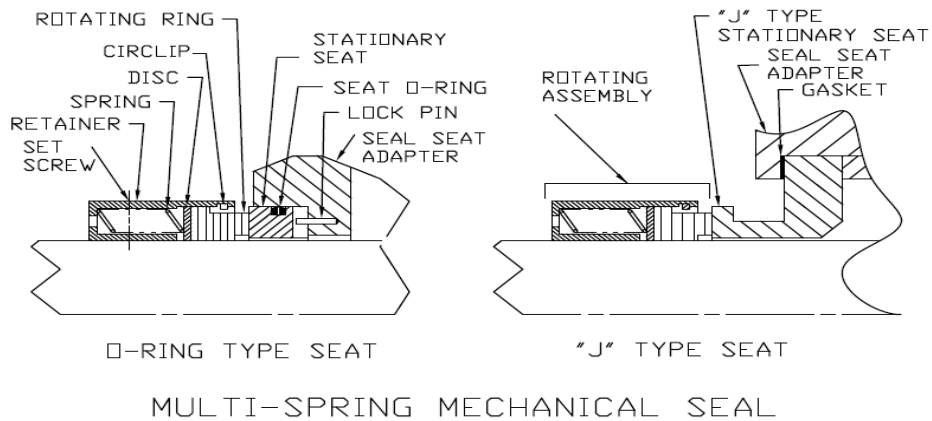
**Table 2 – Pump Operating and Structural Limits**

Maximum Speed.....	3600 RPM for Atex applications. Contact factory for higher speeds. For #6 fuel oil, crude oil and fluids known to contain fine abrasives, pump speed should not exceed 1800 RPM.
Viscosity .....	2.0 cst (33 SSU) Minimum 648 Cst (3000 SSU) max for type B seal. 5400 Cst (25,000 SSU) max for type H seal.
Temperature .....	Type B Mechanical Seal Pumps, 0° to 180°F [-17.8 C to 82.2 C] Type H, N, & J Mechanical Seals, Integral Mounted Pumps, 0° to 250°F [-17.8 to 121 C]
Suction.....	25 PSIG Maximum [1.72 bar Maximum]
Drive .....	Direct Only
Maximum Discharge Pressure .....	150 PSIG [10.3 bar]
Filtration.....	Light Fluids – 60 mesh Heavy Fluids – 1/16 to 1/8 inch [1.58 mm to 3.17 mm]

## MECHANICAL SEAL



**Figure 2 – Single-Spring Mechanical Seal**



**Figure 3 – Multi-Spring Mechanical Seal**

## MAINTENANCE

### GENERAL

To perform maintenance on Series 3E pumps, following conditions shall be completed prior to maintenance action: Close inlet and outlet valves and tag "Out of Service". De-energize pump drive motor controller and tag "Out of Service". Vent all pressure from pump housing. Remove pump from driver and remove coupling from pump. Remove coupling key (13).

**Figures 11 and 13** – No repair kits are offered for these two pump models. The only replaceable part is an O-Ring (26). If O-ring (26) requires replacement please contact your local distributor or the factory for a replacement.

## SERVICING SEAL AND BEARING (refer to Figures 2 and 3, Figures 5 through 8 and 14)

### REMOVAL OF SEAL AND BEARING

Complete GENERAL steps, then remove retainer bolts (6) and retainer (12). Grasp power rotor (7) and pull the assembled power rotor (7) from the pump. Remove O-ring (94) from the Sleeve (93). Disassemble sleeve and power rotor assemblies as follows:

**NOTE:** **Figure 14** has inner and outer Tru-Arch rings (15) installed. When disassembling this model pump the inner True Arch rings (15) cannot be removed prior to pressing the power rotor (7) from the bearing (11). When pressing the bearing from the power rotor the mechanical seal may be damaged. This is of little concern as the mechanical seal must be replaced after the bearing (11) has been removed from the power rotor assembly (7).

- a. **Figures 5 through 8** - Remove outer Tru -Arc ring (15) from the groove of power rotor. Support sleeve assembly (093) and press power rotor (7) down through ball bearing (11) and sleeve assembly (093). **Figure 14** remove inner True-Arch ring (15). Remove mechanical seal seat (Figures 2 and 3) with O-ring (Figures 2 and 3) from sleeve subassembly (093) and remove O-ring from seal seat, if required.
- b. Remove rotating assembly (Figure 2 and 3) of mechanical seal (016) from power rotor (007) as outlined below.
  - (1) **Single Spring (Figure 2)** Slide rotating assembly from power rotor (007).
  - (2) **Multi-Spring (Figure 3)**. Loosen setscrews and slide rotating assembly from power rotor (7).

**NOTE:** If installed idler stop and sleeve are factory assembled on power rotor (007) and should not be removed

### INSTALLATION OF SEAL AND BEARING

Clean and inspect each part for burrs or nicks. Using a buffing wheel, remove all burrs. Particular attention must be given to keyway and Truarc ring groove of power rotor (007) to ensure all sharp edges are removed. Sharp edges on power rotor (007) keyway and truarc ring may cut or shave mechanical seal O-ring when it is placed into installed position. Wipe all parts with lubricating oil (SAE-30) prior to installing.

- a. With power rotor (007) and mechanical seal rotating assembly (Figures 2 and 3) coated with lubricating oil, install the seal rotating assembly (Figure 2 and 3)
  - (1) **Single Spring (Figure 2)**. Slide rotating assembly (on power rotor 7) until rotating assembly is positioned next to idler stop on power rotor 7.
  - (2) **Multi- Spring (Figure 3)**. Slide rotating assembly (on power rotor 7) until rotating assembly is positioned next to idler stop on power rotor 7. Tighten set screws.
- b. Slide mechanical seal O-ring (Figures 2 and 3) in O-ring groove of mechanical seal seat (Figures 2 and 3). Align seat (Figure 2 and 3) slot with spring pin located in sleeve subassembly (093) and slide assembled seat in sleeve subassembly 093. Apply lubricating oil on running faces of mechanical seal seat (Figures 2 and 3). Install O-ring in groove of sleeve sub assembly (093). Install assembled sleeve subassembly on power rotor (007) with seal seat (Figures 2 and 3) contacting installed rotating assembly (Figures 2 and 3).

- c. **Figure 14** - Install inner True-Arch ring (15) in inner snap ring groove of power rotor (7). **Figures 5 through 8 and 14** - Support power rotor (007) and press ball bearing (11) on power rotor (007), pressing only on bearing inner race until bearing just passes retaining ring groove in power rotor. Install True-Arch ring (015) in retaining ring groove ensuring that ball bearing (11) is bottomed out against the sleeve subassembly (093) or Figure 14 the inner race of bearing is just past the out True-Arch ring (15) groove.
- d. Install assembled power rotor, centering each part as it enters cover (004). NOTE: Sleeve subassembly (093) drain port is to be aligned with drain port in cover (004).
- e. Rotate power rotor to ensure freedom of rotation.
- f. Install retainer (012) on cover (004) using bolts (006) tighten to a torque value of 40 lbs. Inch ( $\pm 5$  lbs. inch) [4.5 newton-meters ( $\pm 0.5$  newton meters)]. **Figure 14** - Tighten hex head bolts (6) to a torque value of 75 lbs. Inch ( $\pm 5$  lbs. inch) [101 newton-meters ( $\pm 0.5$  newton meters)].
- g. Install key (013) and coupling hub on power rotor (007). Install pump on driver and check alignment as described in Manual Number SRM 00046 (General Installation, Operation, Maintenance, and Troubleshooting Manual). Prime pump to expel all air prior to starting.

## **DISASSEMBLY AND ASSEMBLY PROCEDURES (Refer to Figures 2 and 3, Figures 5, 6, 7, 8, 12, and 14)**

**Figures 5, 6, 7, 8, and 14** - Disassemble pump by first completing Removal of Seal and Bearing steps under Servicing Seal and Bearing. Continue to disassemble pump as follows:

- a. **(Figures 5, 6, 7, 8, 12, and 14)** Remove bolts (27) and cover (004) from case (001). Remove O-ring (026) from either case (001) or cover (004). **Figure 12** – Remove power rotor (7) ensuring idlers (8) do not fall from pump.
- b. **(Figures 5, 6, 7, 8 and 12)** Remove bolts (003) and cover (002) from case (001). Clean Loctite gasket eliminator from cover (002) and flange of case (001).
- c. **(Figures 14)** Remove bolts (003) and cover (002) from case (001). Remove O-ring 5 from cover (002) or case (001).
- d. **(Figures 5, 6, 7, 8, 12, and 14)** Remove idlers (008) from idler bores if not removed when front cover (4) was removed in step (a).

### **NOTE**

**(Figures 5, 7, and 14)** Iron case pumps where repair kits are offered, do not contain a removable housing. Disassembly is complete for these model pump. Please proceed to step (b) of reassembly.

- e. **Steel Case Pump Only (Figures 6, 8, and 12).** Remove plug (96) and dowel pin (97). Remove housing (032) with O-ring (033) from case (001). Remove O-ring (033) from groove of housing (032).

### **NOTE**

Prior to assembly of pump, check each part and remove any burrs by buffing. Wipe all parts with lubricating oil prior to assembly. Rotate power rotor frequently during assembly to ensure freedom of rotation. Assemble pump as follows:

- a. **Steel case pumps only (Figure 6, 8, and 12):** Install O-ring (033) in groove of housing (032) and install housing (032) in case (001), ensuring that anti-rotation groove in housing (032) is aligned with anti-rotation boss in case (001). Install dowel pin (97) and plug (96) in case.

- b. **(Figures 5, 6, 7, 8, 12, and 14)** Install idlers (008) in housing idler bores (See note on applicable drawing for proper installation of the idlers).
- c. **(Figures 5, 6, 7, 8, and 12)** Wipe all traces of oil from the mating flanges of cover (002) and flanges of case (001). Apply a thin coat of Loctite gasket eliminator No. 504 to cover (002) and flange of case (001). Install cover (002) to case (001) using bolts (003). Torque bolts (003) to a torque value of 170 lbs-inch ( $\pm$  5 lbs-inch) [20 newton-meters ( $\pm$  0.5 newton-meters)].
- d. **(Figure 14)** Wipe all traces of oil from the mating flanges of cover (002) and flanges of case (001). Install O-ring 5 in cover (002). Install cover (002) to case (001) using bolts (003). Torque bolts (003) to a torque value of 170 lbs-inch ( $\pm$  5 lbs-inch) [20 newton-meters ( $\pm$  0.5 newton-meters)].
- e. **(Figures 5, 6, 7, 8, and 14)** Install O-ring (026) over cover (004) flange. Install cover (004) with drain port in case (001) placed in the downward direction using bolts (027). Torque to a value of 170 lbs.-inch ( $\pm$  5 lbs-inch) [20 newton-meters ( $\pm$  0.5 newton- meters)].
- f. **(Figures 5, 6, 7, 8, and 14)** Complete assembly of pump by following steps outlined in Installation of Seal and Bearing.
- g. **(Figure 12)** Install power rotor (7). Install O-ring (026) over cover (004) flange. Install cover (004) using bolts (027). Torque to a value 170 lbs-inch ( $\pm$  5 lbs-inch) [20 newton-meters ( $\pm$  0.5 newton-meters)].

**NOTE**

For pumps equipped with mechanical seals align drain hole in cover (004) with drain in sleeve subassembly (093). The assemblies are equipped with drain ports to prevents fluid being pumped from contaminating ball bearing (011) if mechanical seal failure occurs. Install cover (004) on pump so that drain opening will be the downward direction when pump is installed.

**Table 2 – List of Material for Figures 5 Through 8 and 11 Through 14**

Item	Note*	Part Description	Item	Note*	Part Description
1		Case	19		Name Plate
2	XX	Cover	20		Name Plate
3		Bolt (4)	21		Drive Screw
4	XX	Cover	26	X	O-ring
5		O-ring	27		Bolt (4)
6		Bolt (4)	27		Cap Screw
7	XX	Power rotor Assembly	28		Adapter
8	XX	Idler (2)	32	XX	Housing
11	X	Ball Bearing	33	X	O-ring
12		Retainer	93		O-Ring
13		Key	94	X	O-ring
15	X	Retaining ring			
16	X	Mechanical Seal			
18		Gasket			
<b>Note:</b>	X	Minor Repair Kit Items (iron and steel case pumps).			
	XX	Major Repair Kit Items (steel case pumps only).			
		Items marked X also included in Major Repair Kit.			
<b>ALL QUANTITIES ARE ONE (1) EXCEPT WHEN NOTED IN PARENTHESES AFTER PART DESCRIPTION.</b>					

**REPAIR KITS**

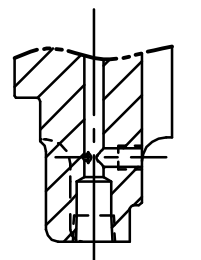
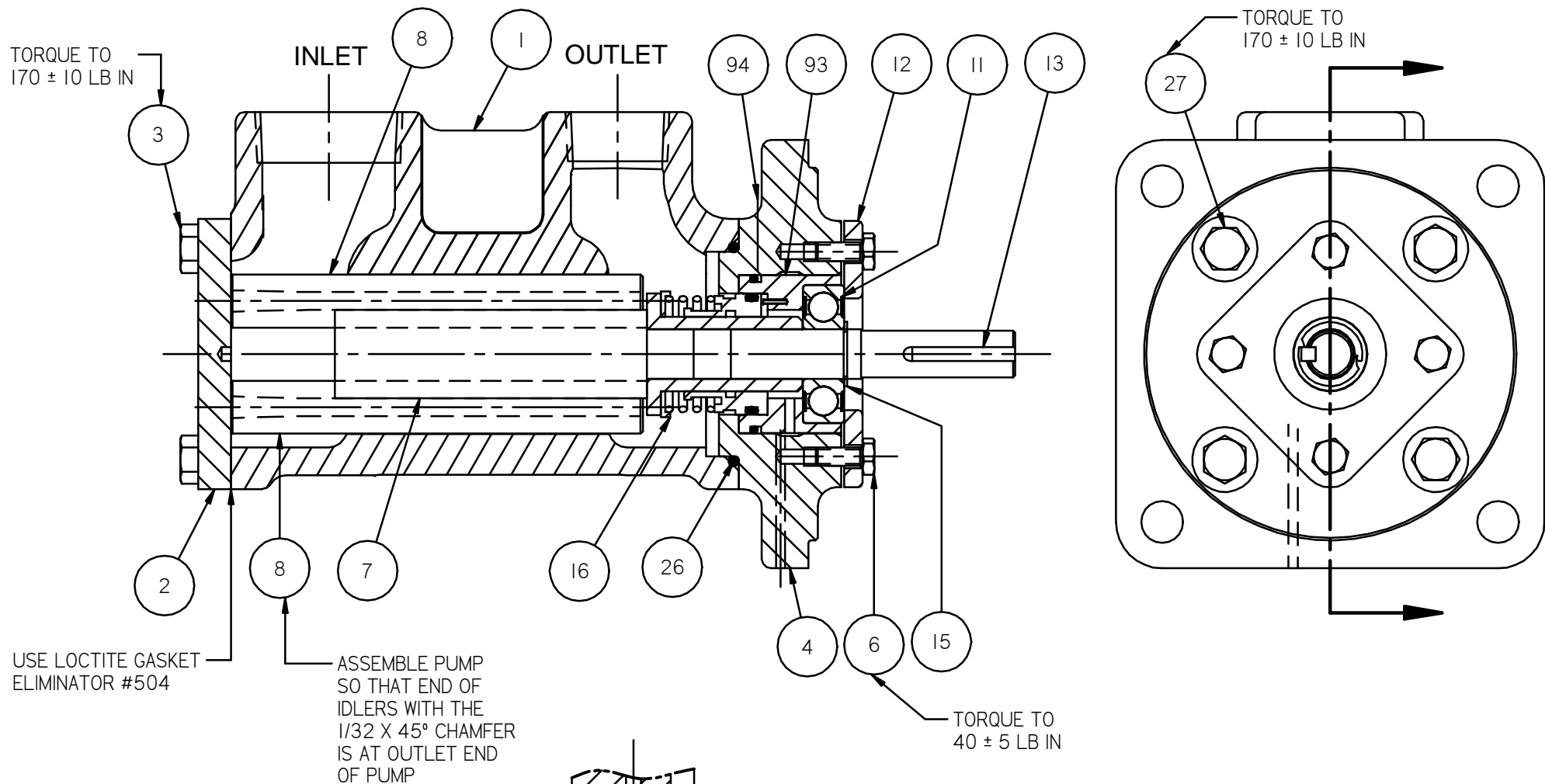


Minor Repair Kits are available for pumps equipped with mechanical seal and ball bearing. Major Repair Kits are available for all steel case pumps. Major Repair Kits are not available for iron case pumps because major repairs are not considered economical. If extensive repair is required to an iron case pump, the pump should be discarded and a new pump purchased. Repair parts are available only in kit form.

## **ORDERING INSTRUCTIONS**

All correspondence pertaining to renewal parts for the equipment must refer to the instruction manual number and should be addressed to the nearest Imo representative. The handling of renewal orders will be greatly facilitated if the following directions are carefully observed:

1. Give the number of the instruction manual with revision level and date.
2. Give the serial number of the pump for which the part is desired. This number appears on the nameplate.
3. Identify the kit (Minor or Major) required.



AUXILIARY SEAL DRAIN

NOTES:

1. DRAIN HOLES IN PART NO. 4 TO BE ASSEMBLED IN THE DOWN POSITION WHEN PUMP IS INSTALLED.
2. SNAP RING TO BE ASSEMBLED WITH SHARP EDGE ON ITS ID FACING TOWARD COUPLING END OF SHAFT. CARE MUST BE TAKEN NOT TO OVERSTRETCH SNAP RING ON ASSEMBLY.

FIGURE 5 IRON CASE C-FACE MOUNT ASSEMBLY

TORQUE TO  
 $170 \pm 10$  FT IN

ASSEMBLE PUMP SO THE END OF  
IDLER WITH  $1/32 \times 45^\circ$  CHAMFER  
IS AT OUTLET END OF PUMP

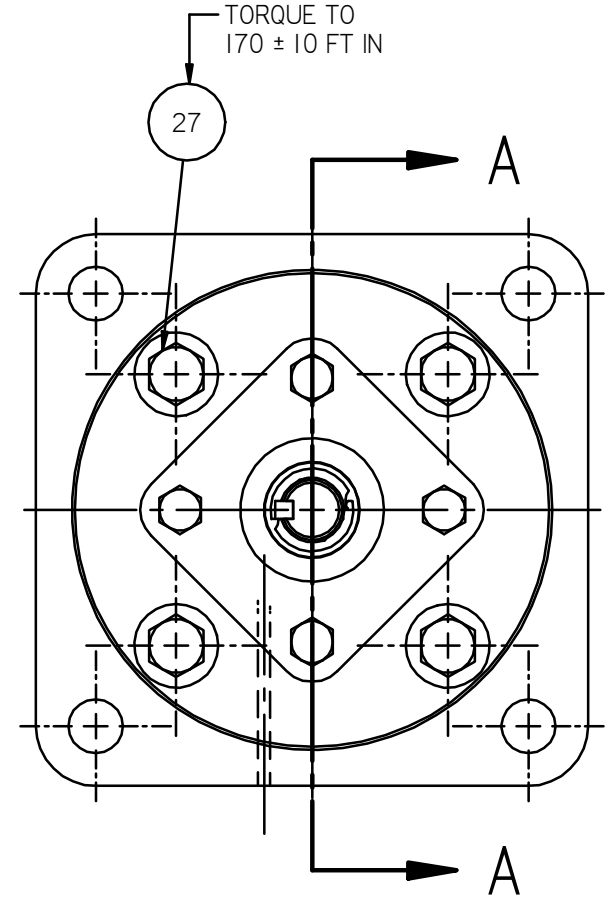
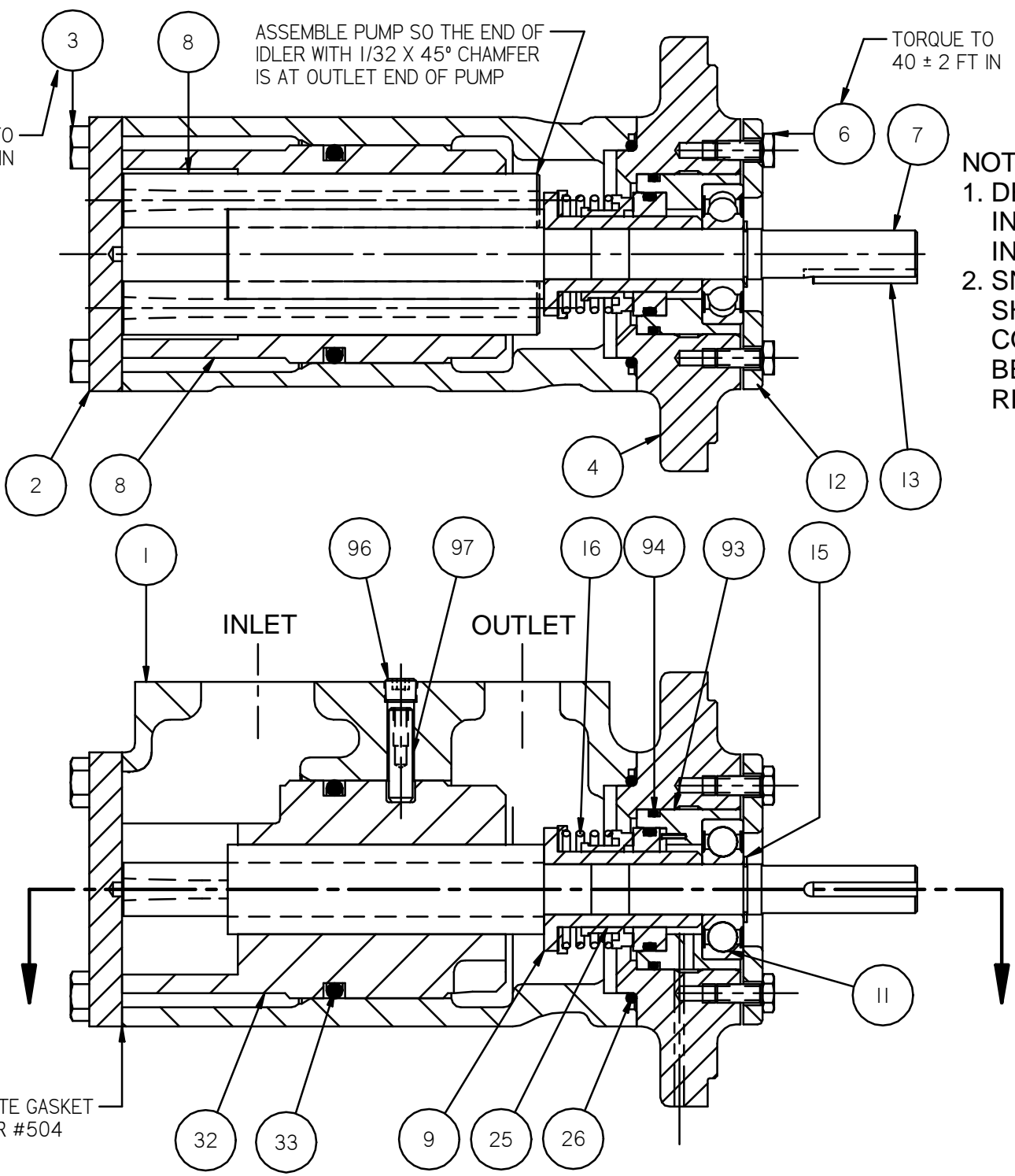
TORQUE TO  
 $40 \pm 2$  FT IN

NOTES:

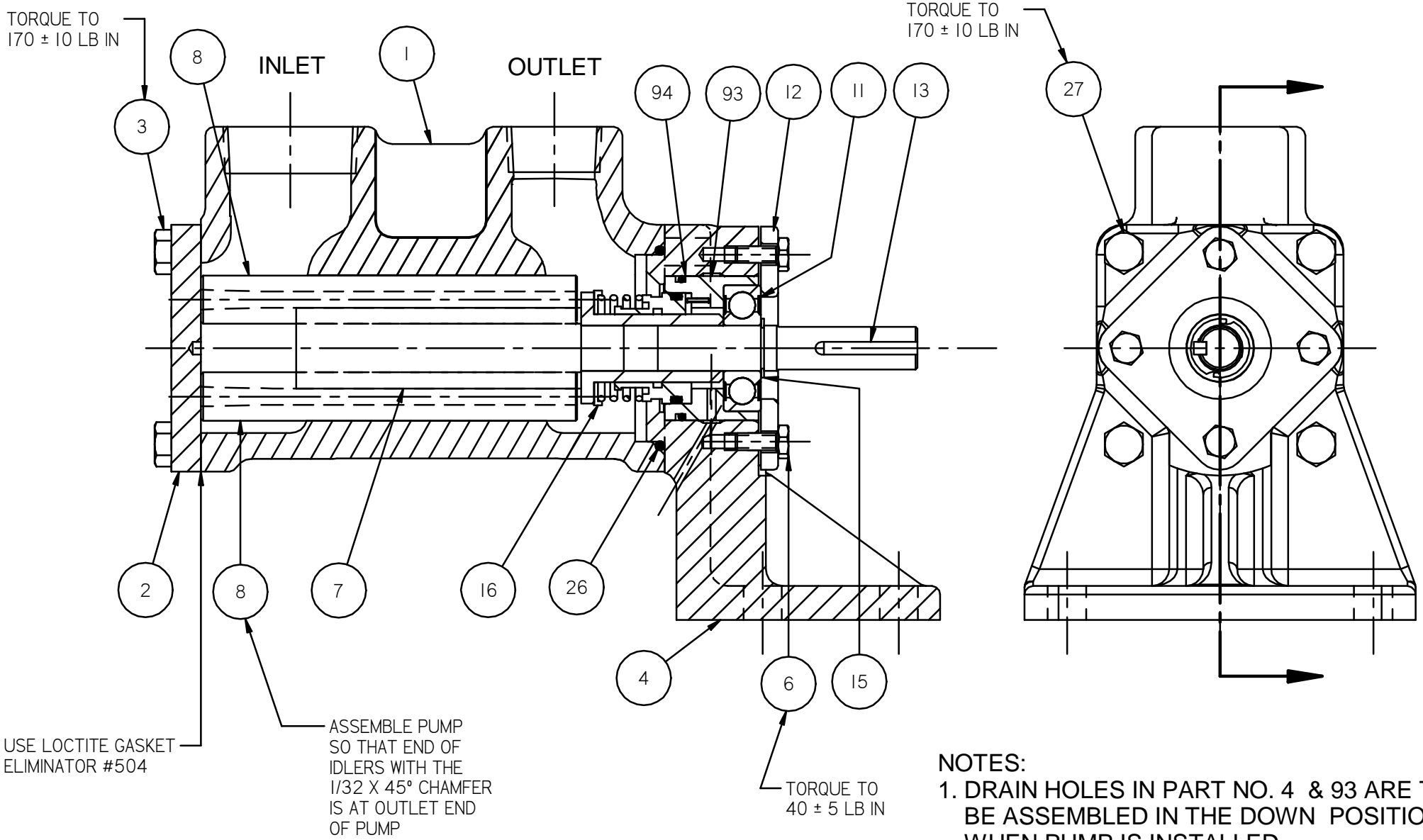
1. DRAIN HOLES IN PART NO. 4 ASSEMBLED IN THE DOWN POSITION WHEN PUMP IS INSTALLED.
2. SNAP RING TO BE ASSEMBLED WITH SHARP EDGE ON ITS ID FACING TOWARD COUPLING END OF SHAFT. CARE MUST BE TAKEN NOT TO OVERSTRETCH SNAP RING ON ASSEMBLY.

TORQUE TO  
 $170 \pm 10$  FT IN

USE LOCTITE GASKET  
ELIMINATOR #504



**FIGURE 6 STEEL CASE C-FACE MOUNT ASSEMBLY**



**FIGURE 7 IRON CASE FOOT MOUNT ASSEMBLY**

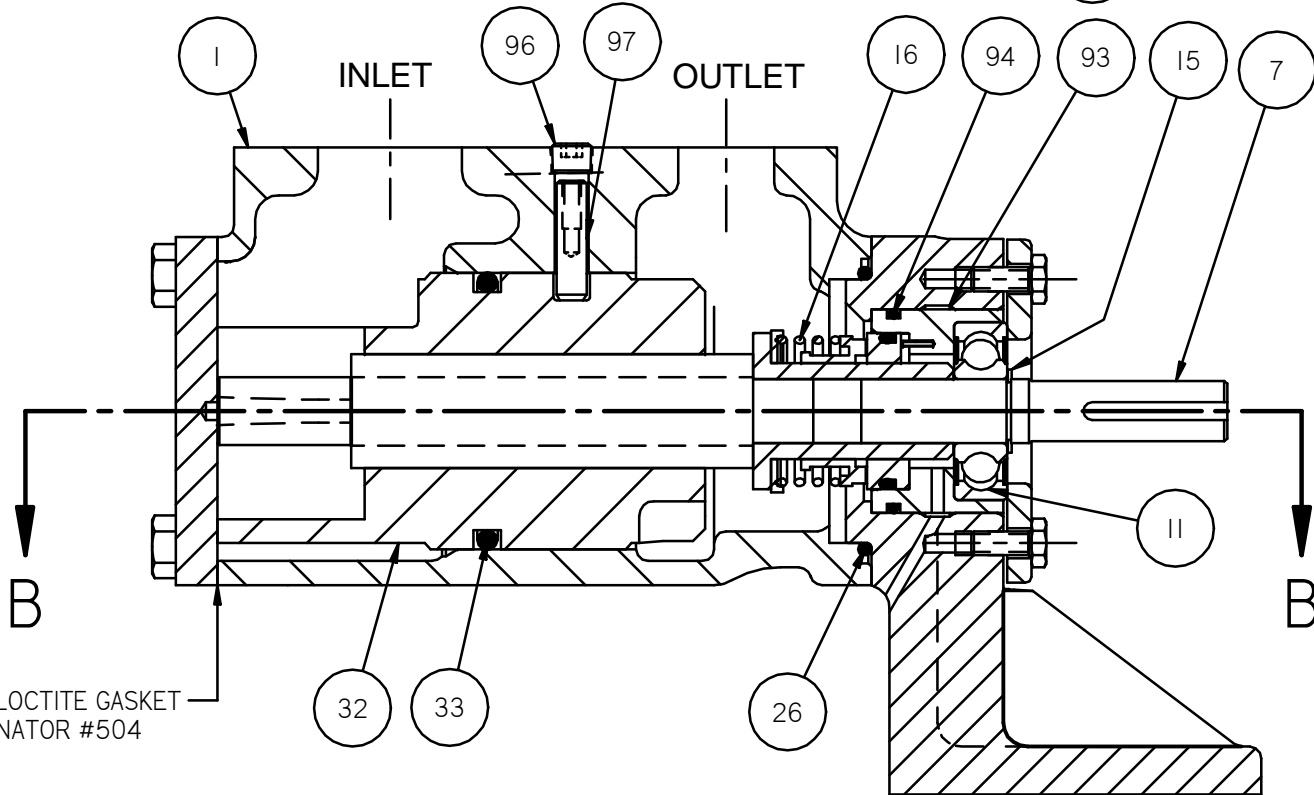
TORQUE TO  
170 ± 10 FT IN

ASSEMBLE PUMP SO THE END OF  
IDLER WITH 1/32 X 45° CHAMFER  
IS AT OUTLET END OF PUMP

TORQUE TO  
40 ± 2 FT IN

NOTES:

1. DRAIN HOLES IN PART NO. 4 & 93 ARE TO BE ASSEMBLED IN THE DOWN POSITION WHEN PUMP IS INSTALLED.
2. SNAP RING TO BE ASSEMBLED WITH SHARP EDGE ON ITS ID FACING TOWARD COUPLING END OF SHAFT. CARE MUST BE TAKEN NOT TO OVERSTRETCH SNAP RING ON ASSEMBLY.



TORQUE TO  
170 ± 10 FT IN

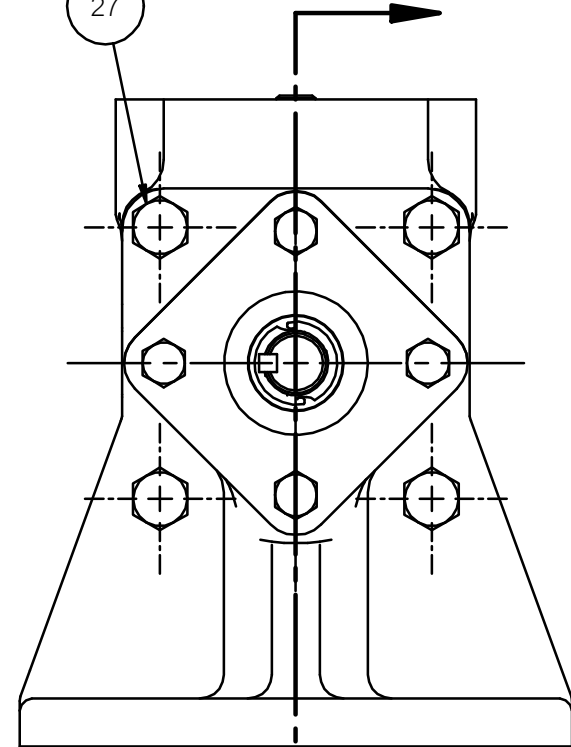
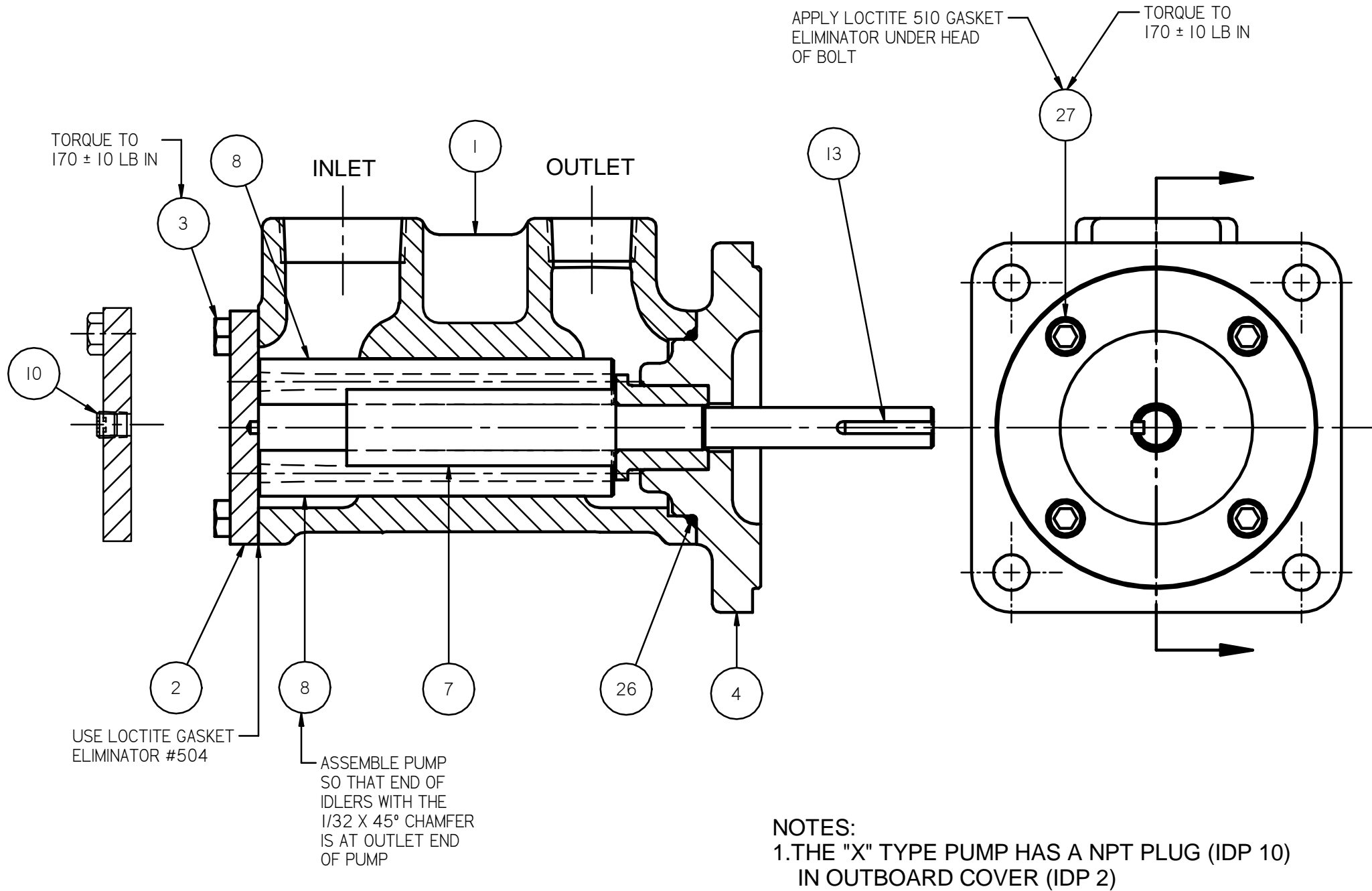
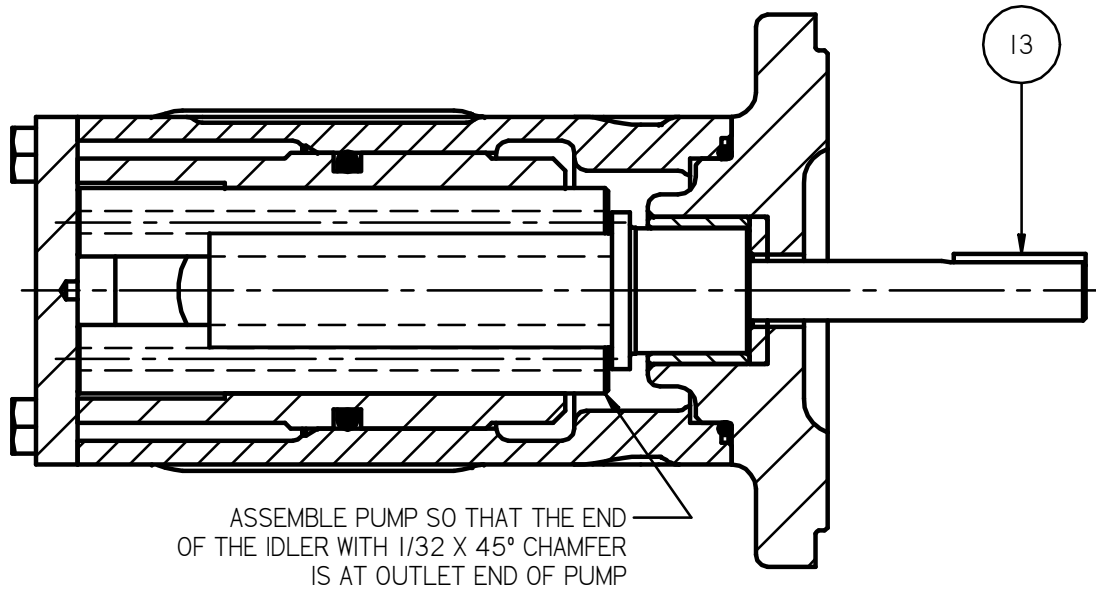
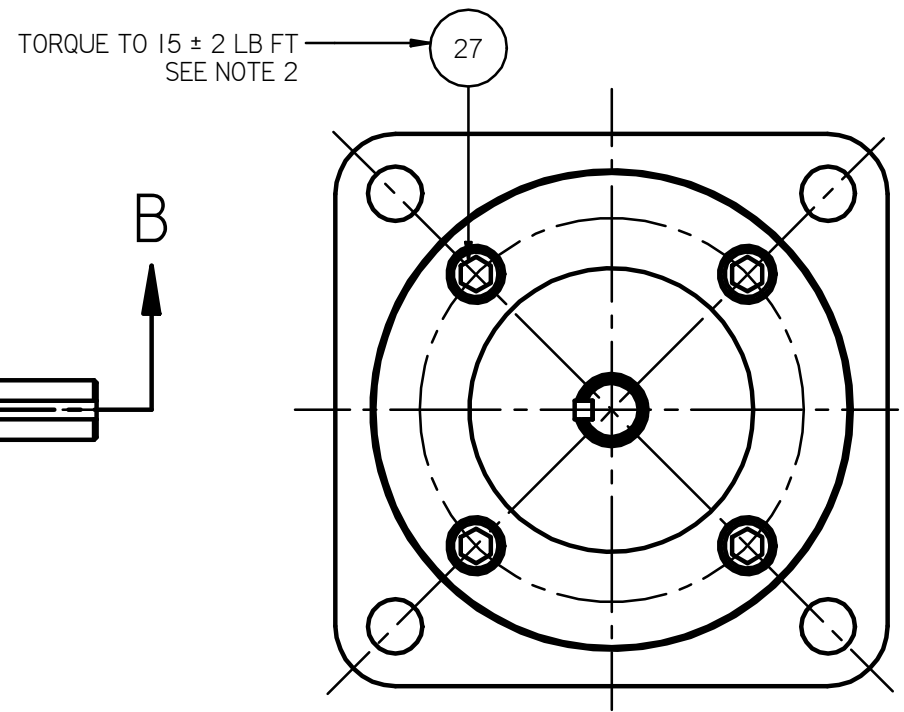
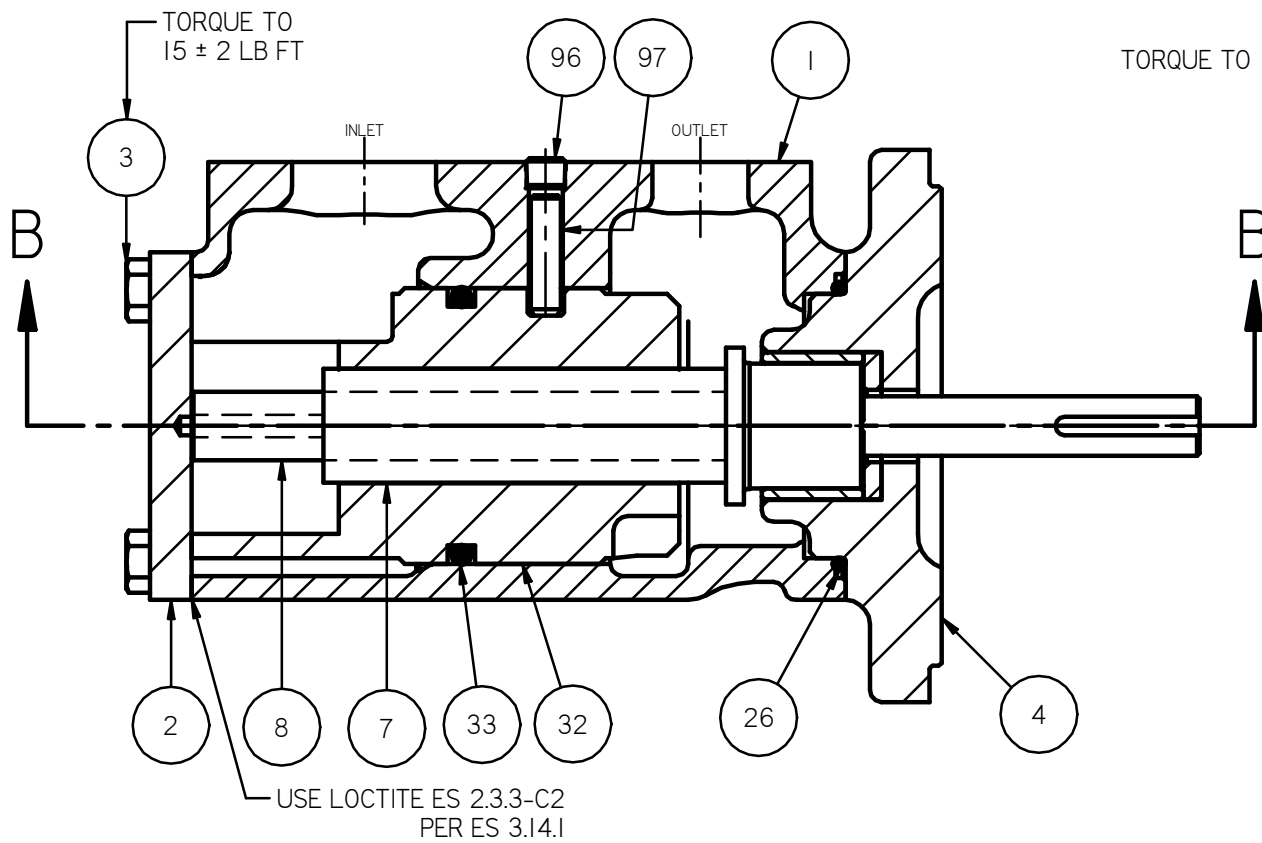


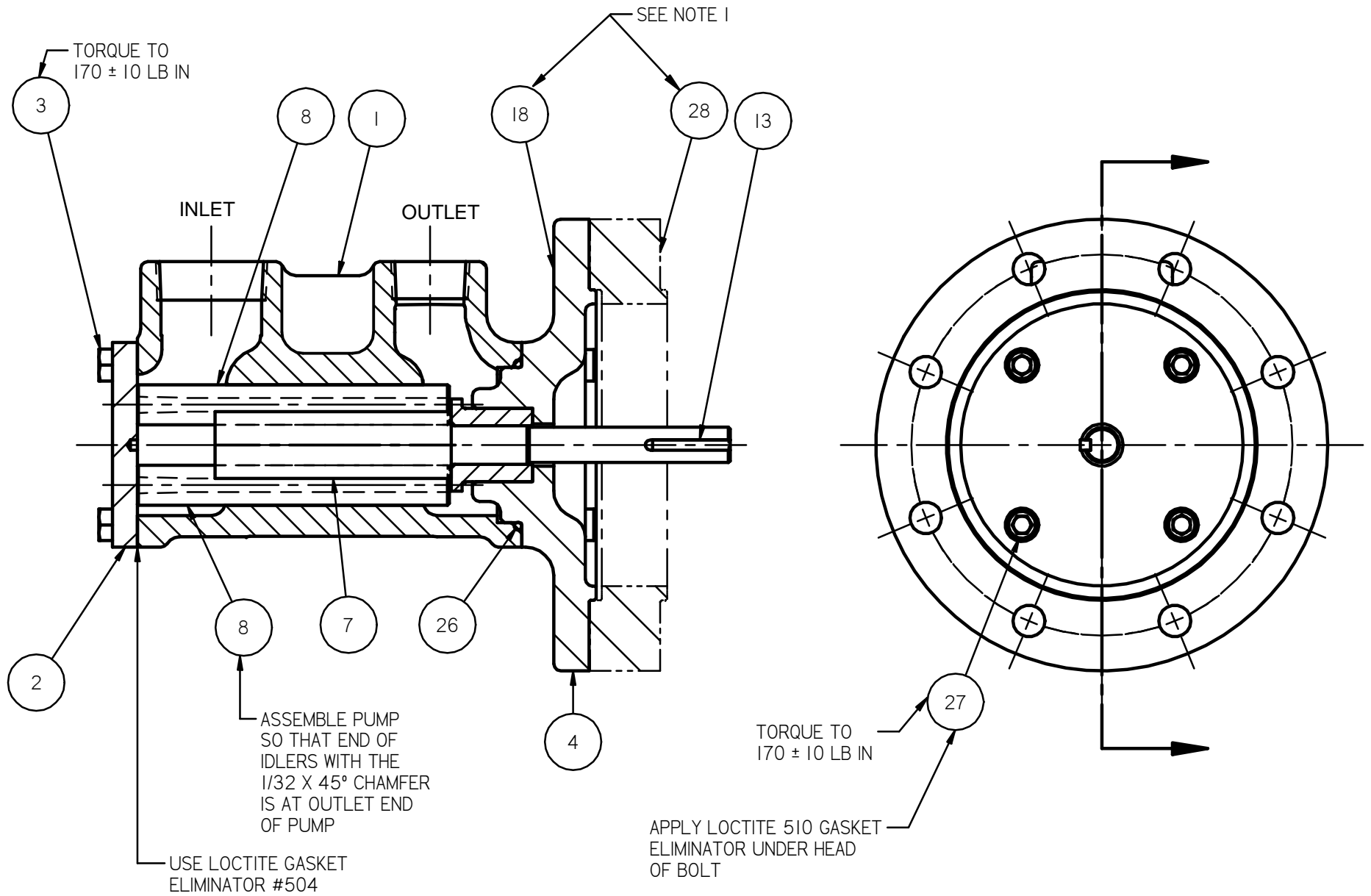
FIGURE 8 STEEL CASE FOOT MOUNT ASSEMBLY



**FIGURE 11 IRON CASE C-FACE MOUNT EIC ASSEMBLY**

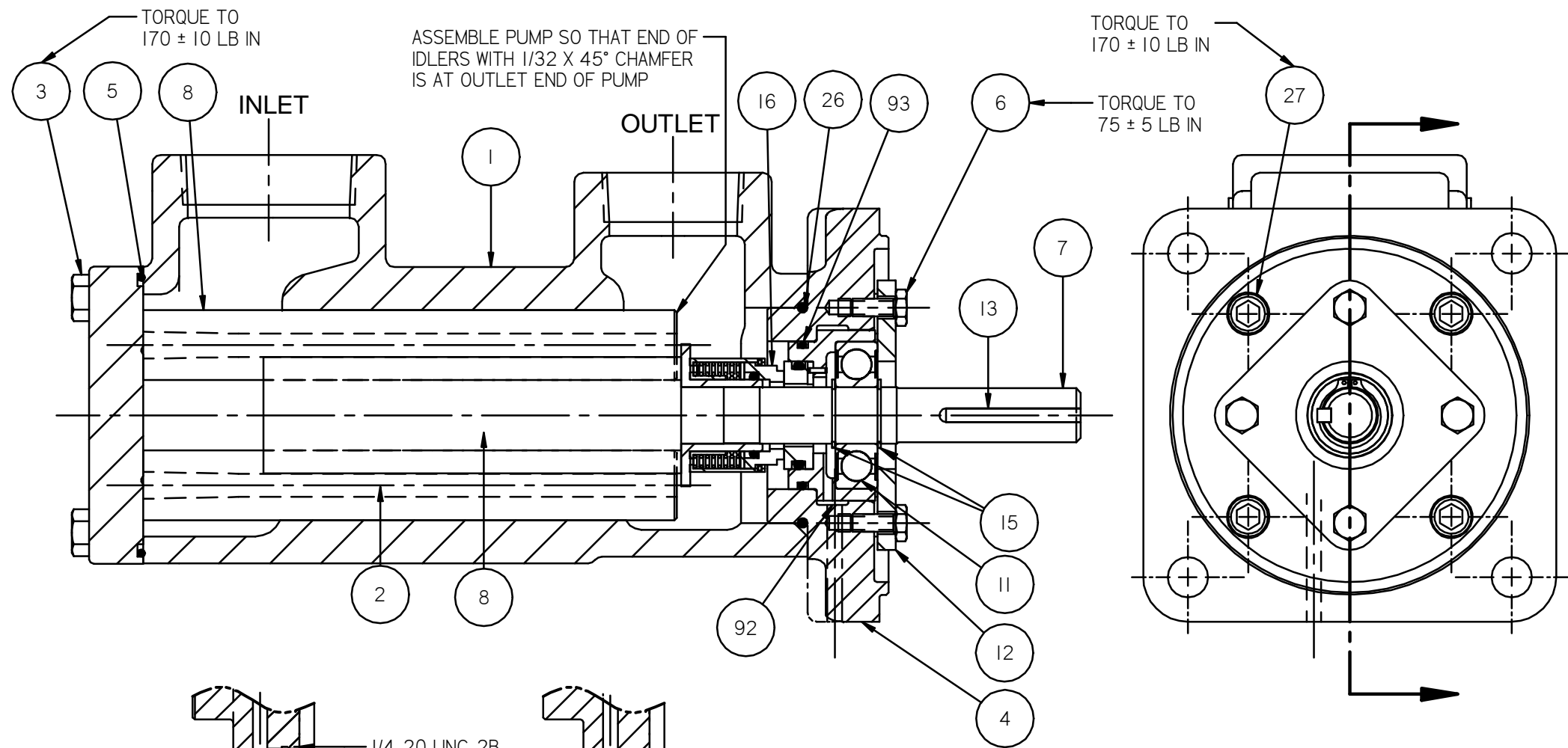


**FIGURE 12 STEEL CASE C-FACE MOUNT EIC ASSEMBLY**



**FIGURE 13 IRON CASE C-FACE MOUNT with BRACKET**

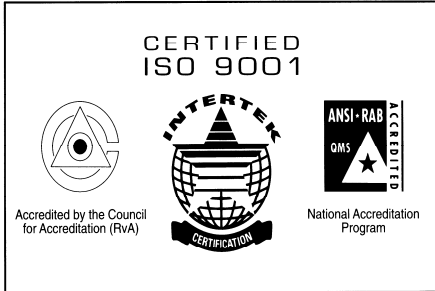




**NOTES:**

1. DRAIN HOLES IN PART NO. 4 & 93 TO BE ASSEMBLED IN THE DOWN POSITION WHEN PUMP IS INSTALLED.
2. SNAP RING TO BE ASSEMBLED WITH SHARP EDGE ON ITS ID FACING TOWARD COUPLING END OF SHAFT. CARE MUST BE TAKEN NOT TO OVERSTRETCH SNAP RING ON ASSEMBLY.

**FIGURE 14 IRON CASE C-FACE MOUNT ASSEMBLY**



**CIRCOR**

1710 Airport Road  
PO Box 5020  
Monroe, NC USA  
28111.5020

*Tel:* +1.877.853.7867

*Email:* [cc@circor.com](mailto:cc@circor.com)

*Web:* [www.circorpt.com](http://www.circorpt.com)