

Original Instructions

CE

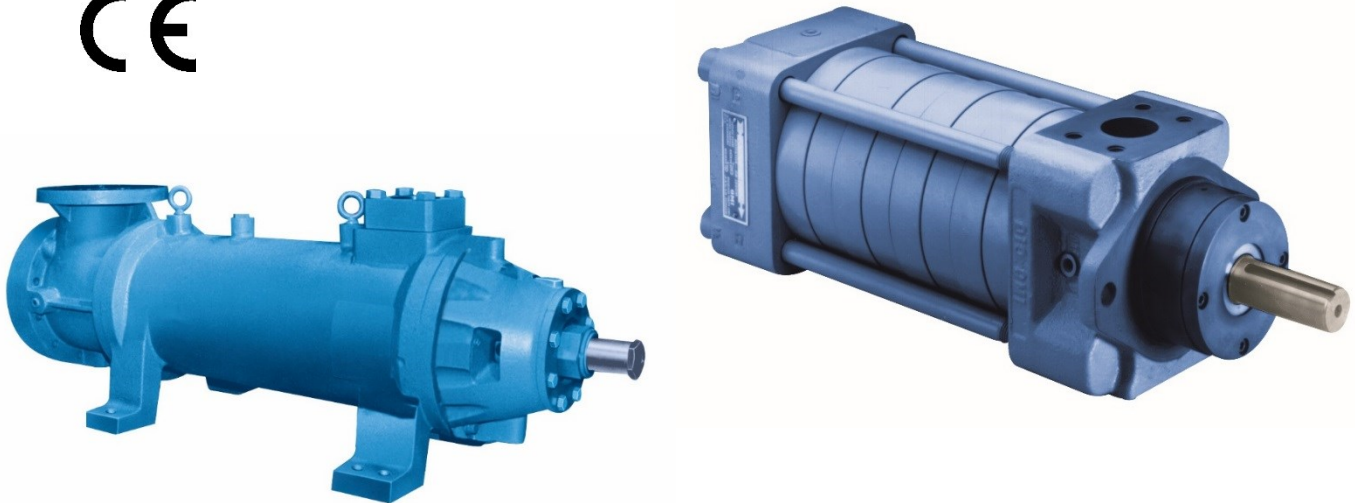

# Imo 3-Screw and CIG Gear Pump Installation, General Maintenance and Troubleshooting Manual

Manual No. SRM00101

Rev. 01 (19-0052)

February 2019



**WARNING**

These instructions should be read thoroughly by all personnel involved with pump operation prior to pump installation, general maintenance or troubleshooting.

# TABLE OF CONTENTS

|  | Page |
|--|------|
| 1. About this Document   |      |
| 1.1 Target Groups .....  | 4    |
| 1.2 Other Applicable Documents .....                               | 4    |
| 1.3 Warnings and Symbols .....                                     | 4    |
| 2. Transport, Storage and Disposal .....                           | 5    |
| 2.1 Transport .....  | 5    |
| 2.1.1 Unpacking and Inspection on Delivery .....                   | 5    |
| 2.1.2 Safe Lifting and Transportation .....                        | 5    |
| 2.2 Storage / Pumps and Spare Parts .....                          | 5    |
| 2.2.1 Treatment for Storage .....                                  | 5    |
| 2.2.2 Storage .....  | 6    |
| 2.2.3 Removing Preservative .....                                  | 6    |
| 2.3 Disposal .....   | 6    |
| 3. Installation .....  | 7    |
| 3.1 Setup Preparation .....  | 7    |
| 3.1.1 Preparing Installation Site .....                            | 7    |
| 3.1.2 Preparing Mounting Surface .....                             | 7    |
| 3.1.3 Foundations and Bedplates .....                              | 7    |
| 3.1.4 Removing Preservative .....                                  | 7    |
| 3.1.5 Installing heat Insulation on Pump .....                     | 8    |
| 3.2 Set Up .....   | 8    |
| 3.3 Installing Driver .....  | 8    |
| 3.4 Preparation for Alignment .....                                | 8    |
| 3.5 Alignment .....  | 9    |
| 3.5.1 Flexible Shaft Couplings .....                               | 9    |
| 3.5.2 Aligning Foot Mounted Pumps and Drivers .....                | 9    |
| 3.5.3 Aligning Flange Mounted Pumps and Drivers .....              | 10   |
| 3.5.4 Belts and Sheaves .....                                      | 11   |
| 3.6 Piping and Valves .....  | 12   |
| 3.6.1 Specifying Supports and Flange Connections .....             | 12   |
| 3.6.2 Relief Valves .....  | 12   |
| 3.6.3 Suction Line .....   | 13   |
| 3.6.4 Suction Strainer and Filter .....                            | 14   |
| 3.6.5 System Filtration .....                                      | 15   |
| 3.6.6 Outlet Filtration .....                                      | 15   |
| 3.7 Connecting Pipes .....   | 16   |
| 3.7.1 Keeping Pipes Clean .....                                    | 16   |
| 3.7.2 Installing Suction Piping .....                              | 16   |
| 3.7.3 Installing Discharge Piping .....                            | 16   |
| 3.7.4 Ensuring Stress Free Pipe Connections .....                  | 16   |
| 3.8 Shaft Packing and Seal Leakage .....                           | 17   |
| 3.9 Quenched Shaft Seals .....                                     | 17   |
| 3.10 Gages .....   | 17   |
| 3.11 Ideal Installation for Pumps Located Above Liquid Level ..... | 17   |

|   |    |
|---|----|
| 3.12 Electrical Connections .....                           | 18 |
| 3.12.1 Connecting Motor .....                               | 18 |
| 4. Operation .....  | 18 |
| 4.1 Putting Pump in Operation .....                         | 18 |
| 4.1.1 Removing Preservative .....                           | 18 |
| 4.1.2 Protective Devices .....                              | 18 |
| 4.1.3 Filling and Bleeding .....                            | 18 |
| 4.1.4 Intermediate Drive Lubrication .....                  | 18 |
| 4.1.5 Heating Jackets .....                                 | 19 |
| 4.1.6 Shaft Seal Quenching Fluid .....                      | 20 |
| 4.1.7 Checking Rotation Direction .....                     | 20 |
| 4.1.8 Switching On .....                                    | 21 |
| 4.1.9 Shaft Seal Leakage .....                              | 22 |
| 4.1.10 Thermal Shock and Operating Temperature Limits ..... | 22 |
| 4.1.11 Switching Off .....                                  | 23 |
| 4.2 Shutting Down Pump .....                                | 23 |
| 4.3 Start up Following a Shutdown Period .....              | 24 |
| 4.4 Operating Standby Pump .....                            | 24 |
| 5. Maintenance .....  | 24 |
| 5.1 Inspection .....  | 25 |
| 5.2 Maintenance .....                                       | 25 |
| 5.2.1 Antifriction Bearings .....                           | 25 |
| 5.2.2 Mechanical Seals, Gaskets, O-rings .....              | 25 |
| 5.2.3 Packing .....   | 26 |
| 5.2.4 Filters and Strainers .....                           | 26 |
| 5.2.5 Alignment .....                                       | 26 |
| 5.2.6 Cleaning Pump .....                                   | 26 |
| 5.3 Repairs .....   | 26 |
| 5.3.1 Returning Pump to Manufacture .....                   | 27 |
| 5.3.2 Removing Pump .....                                   | 27 |
| 5.3.3 Servicing Pump .....                                  | 28 |
| 5.4 Ordering Spare Parts .....                              | 28 |
| 6. Troubleshooting .....                                    | 28 |
| 6.1 Pump Malfunctions .....                                 | 28 |
| 6.2 Relief Valve Malfunctions .....                         | 30 |

## 1. About this Document

This manual:

- Is part of and applies to all Imo and CIG Pump Models / Series
- Provides instructions for safe and appropriate methods for pump installation, general maintenance and troubleshooting.
- Should be used in conjunction with CE “Safety and Operation Manual” (SRM00100) and individual pump “Product Service Manual”.



### 1.1. Target Groups

| Target Group                            | Duty  |
|---|---|
| Operating Company                       | <ul style="list-style-type: none"> <li>• Keep manual available at site of operation of equipment, including for later use.</li> <li>• Ensure personnel read and follow instructions in manual and other applicable documents, especially all safety instructions and warnings.</li> <li>• Observe any additional rules and regulations referring to your system.</li> </ul> |
| Qualified Personnel, Fitters, Operators | <ul style="list-style-type: none"> <li>• Read, observe and follow these manual and other applicable documents, especially all safety instructions and warnings.</li> </ul>  |

### 1.2. Other Applicable Documents

| Document                                     | Purpose  |
|--|--|
| Product Service Manual                       | Detailed instructions, assembly drawing and parts lists specific to pump series and size.    |
| Safety and Operation Manual (SRM00100)       | General information about safety and operation of Imo three screw and CIG pumps, (SRM00100). |
| ATEX additional instructions (If Applicable) | Operation in explosion-hazard areas (SRM00092).  |
| Order data sheet                             | Technical specifications, conditions of operation.   |

### 1.3. Warnings and Symbols

| Warning   | Risk Level                      | Consequences of Disregarding Warning |
|---|---------------------------------|--------------------------------------|
|  DANGER  | Immediate Acute Risk            | Death, Serious Bodily Harm           |
|  WARNING | Potential Acute Risk            | Death, Serious Bodily Harm           |
|  CAUTION | Immediate Hazardous Situation   | Minor Bodily Harm, Material Damage   |
| NOTE  | Potentially Hazardous Situation | Minor Bodily Harm, Material Damage   |

## 2. Transport, Storage and Disposal

2.1. Transport - Pump weights are clearly and durably marked on pump nameplate.

### 2.1.1 Unpacking and Inspection on Delivery

1. Unpack pump/unit upon delivery and inspect it for transport damage.
2. Report any transport damage to manufacturer immediately.
3. Leave protective covers on all openings until just prior to attaching system piping.
4. Dispose of packaging material according to local regulations.

### 2.1.2 Safe Lifting and Transportation

|  <b>DANGER</b>  |
|--|
| <p><b>Death or crushing of limbs caused by falling or overturning loads!</b></p> <ul style="list-style-type: none"><li>- Use properly rated lifting devices appropriate for total unit weight.</li><li>- Ensure unit's center of gravity is located between lifting points.</li><li>- Use spreader bars as necessary to ensure load is properly distributed.</li><li>- Take precautions to prevent slippage of slings and hooks.</li><li>- For vertical transport: Provide a securing rope between hood and load eyebolt of motor.</li><li>- Never fasten lifting gear onto motor eyebolt (unless used as a safety device against tipping over for units with a high center of gravity).</li><li>- Do not stand under suspended loads.</li></ul> |

Fasten lifting gear as shown in following illustration (Figure 1):

Figure 1 – Lifting Illustration

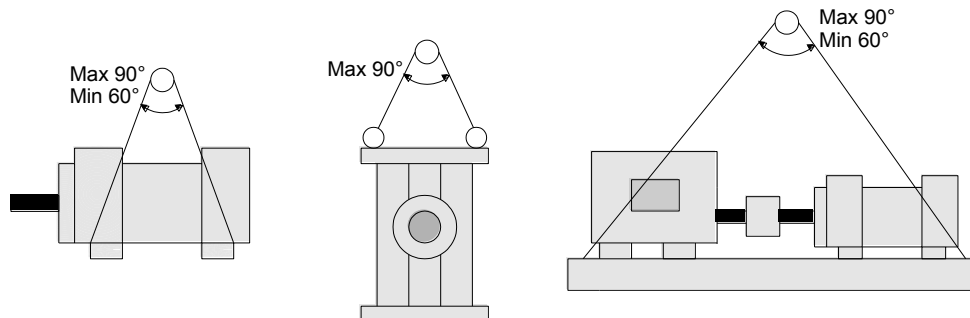

## 2.2. Storage / Pumps and Spare Parts

### 2.2.1. Treatment for Storage

- 2.2.1.1. From factory, pump is delivered with protective covers in or over all openings and with internals filled with oil or with PL-2, unless specified otherwise by customer order.

**2.2.1.2.** IF pumps are to be stored in other than a clean, warm, or dry environment, or if they are to be stored for more than six months, follow below procedure:

1. Set pump down so that pressure-side flange is higher than suction-side flange.
2. Close suction-side flange with a blank flange.
3. Fill pump with preservative (e.g. PL-2 or equivalent).
4. Turn shaft slowly in opposite direction of pump's indicated rotation.
5. Continue filling and turning until preservative escapes from pressure flange without bubbles.
6. Close pressure-side flange with a blank flange.
7. Renew preservative every 6 months if necessary
8. Apply preservative to all bare metal parts on outside of pump.

**2.2.2. Storage**

**NOTE**

**Material Damage Due to Inappropriate Treatment for Storage!**  
 - Material damage can result due to improper storage.

1. Seal all openings with blank flanges, blind plugs or plastic covers.
2. Be sure storage room meets following conditions:
  - Dry
  - Frost-free
  - Vibration-free
  - Dust –free
3. Turn shaft once a month.
4. Make sure shaft and bearing change their rotational position in the process.

**2.2.3. Removing Preservative-Only Necessary for Pumps Treated for Storage**

**NOTE**

**High Water Pressure or Spray can Damage Bearing!**  
 - Do not clean bearing areas with water or steam jet.

1. Choose cleaning agent according to application.
2. Remove preservative from all bare internal parts of pump.
3. Dispose of cleaning agents in accordance with local regulations.
4. For storage times in excess of 6 months:
  - Replace elastomeric parts made of EP rubber (EPDM).
  - Check all elastomeric parts (O-rings, shaft seals) for proper elasticity and replace if necessary.

**2.3. Disposal**

 **WARNING**

**Risk of Poisoning and Environmental Damage by Pumped Liquid or Oil**  
 - Use personal protective equipment when carrying out any work on pump.  
 - Prior to disposal of pump.  
 - Collect and dispose of any escaping pumped liquid or oil in accordance with local regulations.  
 - Neutralize residue of pumped liquid in pump.

Dispose of pump in accordance with local regulations.

### 3. Installation

For pumps in explosion-hazard areas see ATEX additional instructions (SRM00092).

| NOTE  |
|---|
| <b>Material damage due to distortion or passage of electrical current in bearing!</b><br>- Do not make any structural modifications to pump or pump unit.<br>- Do not carry out any welding work on pump unit or pump casing. |

| NOTE   |
|--|
| <b>Material damage caused by dirt!</b><br>- Do not remove any port covers until immediately before connecting pipes to pump to prevent ingestion of contamination particles. |

#### 3.1. Setup Preparation

##### 3.1.1. Preparing Installation Site

Ensure installation site meets following conditions:

- Pump is freely accessible from all sides
- Pump is near liquid source and preferable placed so pump centerline is below liquid surface.
- Sufficient space for routine visual inspection, onsite service and maintenance, and pump replacement.
- For large units, ample overhead clearance should be provided to allow for lifting device maneuvering.
- Pump is not exposed to external vibrations (damage to bearings)
- Frost protection

##### 3.1.2. Preparing Mounting Surface

Be sure mounting surface meets following conditions:

- Level
- Clean (no oil, dust or other impurities)
- Capable of bearing weight of pump unit and all operating forces
- Pump is stable and cannot tip over

##### 3.1.3. Foundations and Bedplates

Foundations and baseplates must be designed and installed so pump and driver alignment can be maintained at all times. Small pumps may be mounted on baseplates or directly to existing floors that meet criteria of foundations. Larger pumps must be mounted to baseplates and foundations.

Make sure foundation or baseplate meets following conditions:

- Level and resting on smooth flat surface.
- It is recommended that pumps and their drivers be mounted on common baseplates

##### 3.1.4. Removing Preservative

If pump is to be put into operation immediately after setup and connection: Remove preservative prior to setup.

### 3.1.5. Installing heat Insulation on Pump

Only necessary in high temperature applications with heater in tank or where temperature of pumped fluid at startup could be 50°F greater than pump temperature.

| NOTE   |
|--|
| <b>Material damage on bearing or shaft seal due to overheating!</b><br>- Only install heat insulation on pump casing not on shaft end cover. |

Install insulation properly according to manufacturers' instructions.

### 3.2. Set Up

1. If pump is set up in vertical position, install pump unit with pump bracket on cover of tank or stand.
2. If pump is set up in horizontal position:
  - Install pump unit with mounting feet on a level surface.
  - Ensure that seal leak detection hole points down.
  - Ensure seal vent connection faces up.

### 3.3. Installing Driver

Only necessary if pump unit is assembled on site.

| NOTE  |
|---|
| <b>Material damage caused by knocks and bumps!</b><br>- Keep coupling halves properly aligned when slipping them on.<br>- Do not knock or hit any components of pump. |

### 3.4. Preparation for Alignment

On horizontal pump/driver assemblies, shaft couplings are often shipped disassembled to prevent coupling damage during shipping and handling.

When not supplied by manufacturer, coupling, shaft and/or belt guards conforming to 2006/42/EC must be installed during pump operation.

For pumps shipped on baseplates without drivers:

1. Install and tighten each coupling half on driver and pump shafts.
2. Place driver on baseplate and set proper distance between shafts and coupling hubs.
3. Locate driver so pump and driver shafts are in axial alignment.

For pumps driven through separate gear box or other device, first align device relative to pump, then align driver relative to device.

For belt driven pumps, Final alignment of pump and driver should take place after unit is secured to foundation. If baseplate is to be grouted, this should be completed before final alignment.



**NOTE**

**Material damage caused by lateral shifting of baseplate!**

- Grouting is recommended to prevent lateral shifting of baseplate.
- A baseplate designed specifically for this purpose is required

**⚠ WARNING**

**Risk of injury due to personnel contact with rotating couplings, belts, sheaves, chains, shafts and/or keyways!**

- Ensure all coupling set screws and bolts are tight and coupling gap is properly. Install guards over couplings and shaft to protect personnel.
- Ensure all coupling set screws and bolts are tight and coupling gap is properly set.

### 3.5. Alignment

All pump and driver assemblies must be aligned after site installation and at regular maintenance intervals. This applies to factory mounted units (new or rebuilt) because factory alignment is often disturbed during shipping and handling. Flexible couplings shall be used to connect pump to its driver unless otherwise specified by manufacturer.

Objective of any aligning procedure is to align shafts (not align coupling hubs) by using methods that cancel out any surface irregularities, shaft-end float and eccentricity.

#### 3.5.1. Flexible Shaft Couplings

Flexible couplings are intended to provide a mechanically flexible connection for two aligned shaft-ends. Flexible couplings are not intended to compensate for major angular or parallel shaft misalignment. Allowable misalignment varies with type of coupling. Any improvement in alignment beyond coupling manufacturer's minimum specification will extend pump, mechanical seal or packing, coupling, and driver service life by reducing bearing loads and wear.

**NOTE**

**Material damage due to shaft misalignment!**

- Establish and maintain proper alignment to obtain proper operation and maximum life.
- Align pump-to-driver shaft alignment in accordance with pump's alignment requirement, regardless of coupling manufacturer's stated limits.
- Ensure all coupling set-screws and bolts are tight and coupling gap is properly set.

#### 3.5.2. Aligning Foot Mounted Pumps and Drivers

**Figure 2 Foot Mounted Pump**

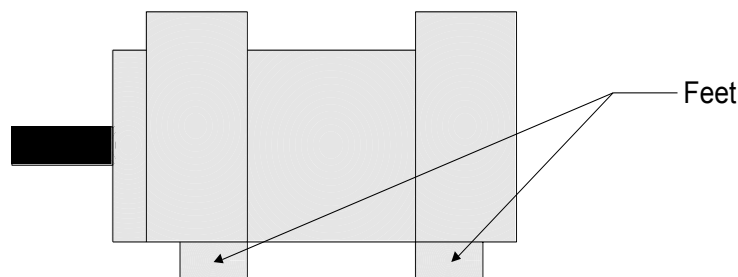

To install foot mounted pump and driver:

1. Install pump and driver onto baseplate after installing appropriate coupling halves on pump and driver shafts
2. Perform alignment of pump and driver shafts using dial indicators. Acceptable alignment has been attained when FIM (Full Indicator Movement) is less than or equal to 0.005 inch (0.12 mm) for face (angularity) and rim (parallelism) readings at or near coupling outer diameter while rotating both shafts together one full turn (360°).

**Figure 3 Coupling and Hub Alignment**

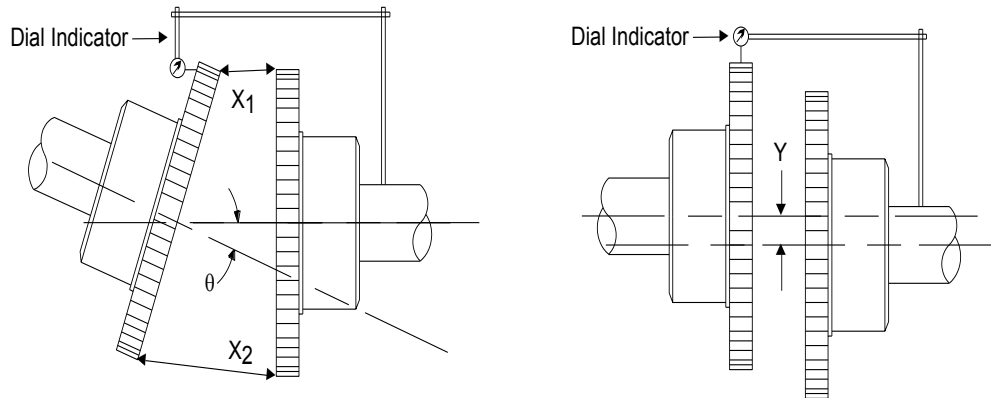

### 3.5.3. Aligning Flange Mounted Pumps and Drivers

**Figure 4 Flange Mounted Pump**

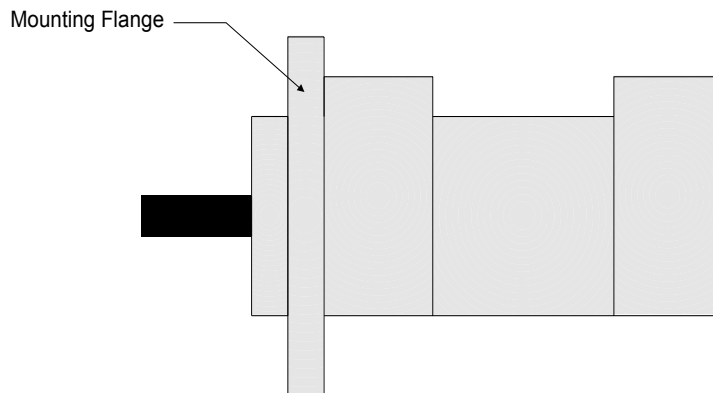

**NOTE**

**Material Damage Due To Shaft Misalignment!**

- Do not assume bracket will automatically align pump and driver shafts.
- Design bracket to obtain and maintain required alignment as well as to support pump weight plus any residual piping forces.

If a right-angle foot bracket is used:

1. Mount pump onto bracket and tighten pump to bracket mounting bolts.
2. Bracket base is, in effect, pump feet. Continue with aligning procedure as if pump were foot mounted

3. If bracket design includes adequate room, check shaft alignment with dial indicators with both pump and driver mounted onto bracket. If this is not possible, align bracket to driver shaft, then attach pump to bracket. Acceptable alignment has been attained when FIM (Full Indicator Movement) is less than or equal to 0.005 inch (0.12 mm) for face (angularity) and rim (parallelism) readings at or near coupling outer diameter while rotating both shafts together one full turn (360°).
4. After pump-bracket-driver is installed into system and after piping is connected to pump, recheck shaft alignment. Adjust shaft alignment if necessary

**Figure 5 Alignment of Flange Mounted Pumps**

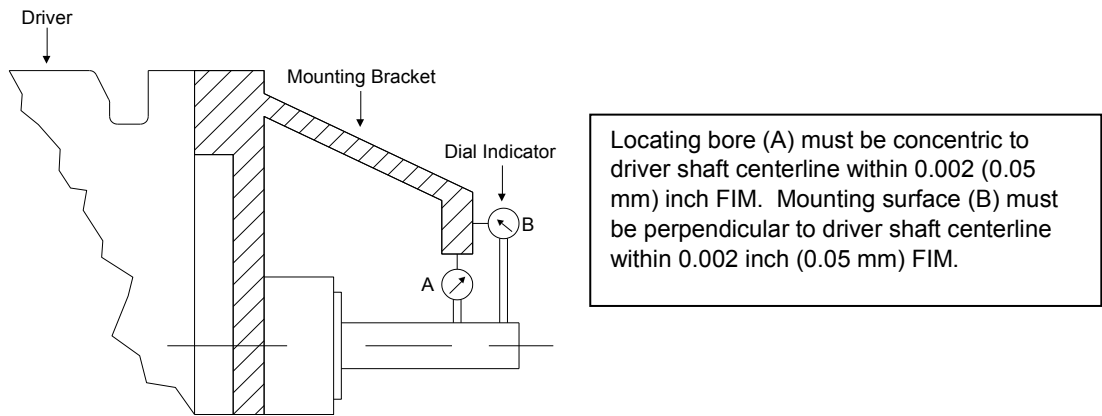

### 3.5.4. Belts and Sheaves

Contact manufacturer to determine if a particular pump can be belt driven.

|   |
|---|
| <b>⚠ WARNING</b>  |
| <b>Risk of injury due to personnel contact with rotating couplings, sheaves, chains, shafts and/or keyways!</b>   |
| <ul style="list-style-type: none"> <li>- Ensure all coupling set screws and bolts are tight and coupling gap is properly set.</li> <li>- Install guards over couplings and shaft to protect personnel.</li> </ul> |

|   |
|---|
| <b>NOTE</b>   |
| <b>Material damage caused by improper use of belt drive!</b>  |
| <ul style="list-style-type: none"> <li>- Use belt drive ONLY on pumps specifically designed for this purpose.</li> <li>- Do not belt drive pumps with ratings in excess of 600 psi differential pressure without manufacturer approval</li> </ul> |

|  |
|--|
| <b>NOTE</b>  |
| <b>Material damage caused by improperly installed belt drive!</b>  |
| <ul style="list-style-type: none"> <li>- Properly select, align and tension belts and sheaves to minimize belt wear, eliminate possibility of belt turnover in sheave grooves, and avoid excessive side load on pump shaft.</li> <li>- Properly tension belts to avoid noise and overheating of sheaves.</li> <li>- Properly tension belts to avoid bearing failure, shaft failure or reduced bearing life.</li> </ul> |

Use adjustable slide rails mounted under driver for proper belt tensioning.  
 Check belt tension frequently during first 24 to 48 hours of run-in operation.  
 Follow belt drive manufacturer's recommendations for alignment of sheaves and belt-tension settings.

### 3.6. Piping and Valves

#### 3.6.1. Specifying Supports and Flange Connections

| NOTE   |
|--|
| <b>Material damage due to excessive forces and torques exerted by piping on pump!</b><br>- Do not exceed permissible values of flange loads according to pump outline drawing,<br>See EN ISO 14847 and API 676 |

Calculate pipe forces, taking all possible operating condition into account:

- Cold/warm
- Empty/full
- Depressurized/pressurized
- Positional changes of flanges
- Ensure pipe supports have permanent low-friction properties and do not seize up due to corrosion.
- Ensure piping connected to pump is independently supported and not allowed to impose strains on pump casing, including allowing for expansion and contraction due to pressure and temperature changes.
- Ensure all return lines in recirculating systems end well below liquid surface in reservoir.
- Install shut-off valves in both suction and discharge lines to hydraulically isolate pump for service or removal.

#### 3.6.2. Relief Valves

Always use relief valves to protect pumps from overpressure. Three screw and CIG series pumps are positive displacement types. They will deliver (or attempt to deliver) flow regardless of back-pressure on unit. Failure to provide pump overpressure protection can cause pump or driver malfunction and rupture of pump or piping.

Some low pressure pump models include built-in safety relief valves. They are intended only for emergency operation, NOT for system control. Extended operation of relief valves in these pumps could lead to pump damage or failure.

|  <b>DANGER</b>  |
|--|
| <b>Risk of death or injury due to pump rupture or pipe rupture!</b><br>- Provide pump overpressure protection to prevent pump or driver malfunction and rupture of pump or piping. |

|  <b>WARNING</b>  |
|---|
| <b>Risk of injury due to excessive pressure!</b><br>- Do not set relief valve higher than maximum pressure rating of pump, including pressure accumulation at 100% bypass |

| NOTE   |
|--|
| <b>Material damage due to temperature rise caused by return lines piped back to pump inlet!</b><br>- Bypass liquid from relief pressure and flow control valves should be returned to source (tank, reservoir, etc.) not pump inlet. |

1. Observe operating instructions of manufacturer.
2. Make sure factory setting of pressure relief valve meets requirements of system.

3. Do not allow safety valve return to flow directly back into suction pipe.
4. Connect relief valve in pump discharge line as close to pump as possible with no other valves between pump and relief valve.
5. Set relief valve as low as practical

**Figure 6 Proper Relief Valve Return Line Arrangement**

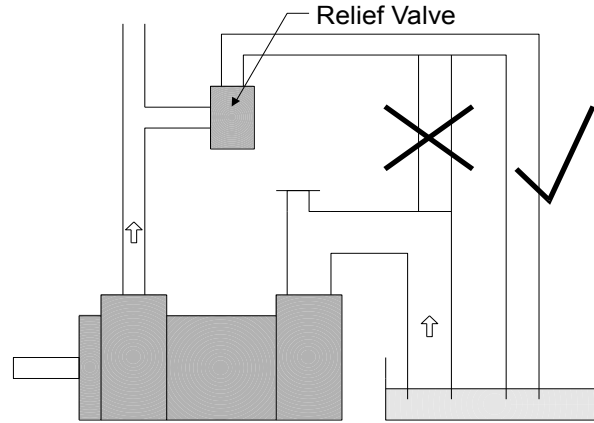

### 3.6.3. Suction Line

Suction line should be designed so pump inlet pressure, measured at pump inlet flange, is greater than or equal to minimum required pump inlet pressure (also referred to as Net Positive Inlet Pressure Required or NPIPR).

1. Suction line length should be as short as possible.
2. Suction line diameter should be equal to or larger than pump's inlet size.
3. All joints in suction line **MUST** be tight and sealed.

If pump cannot be located below liquid level in reservoir, position suction line or install a foot valve so liquid cannot drain from pump while it is shut down.

When pump is mounted vertically with drive shaft upward or mounted horizontally with inlet port opening other than facing upward, a foot valve or liquid trap should be installed in suction line to prevent draining.

**Figure 7 Fluid Trap and Foot Valve Arrangements for Vertical Pumps**

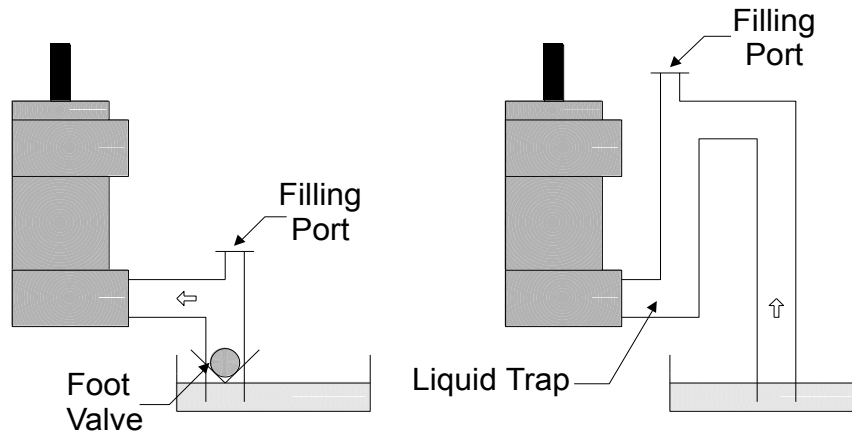

| NOTE  |
|---|
| <p><b>Material damage caused by dry running or severe cavitation!</b><br/> <b>- Ensure suction line and pump is filled properly before pump start-up!</b></p> |

Fill suction line and pump before pump start-up.

### 3.6.4. Suction Strainer and Filter

| NOTE  |
|---|
| <p><b>Material damage caused by debris in piping entering pump!</b></p> <ul style="list-style-type: none"> <li>- Before connecting pump to system, flush all system piping thoroughly to remove debris accumulated during fabrication, storage, and installation.</li> <li>- Imo pumps are not for flushing. Ensure suction line between suction strainer and pump is clean.</li> </ul> |

Pump life is related to liquid cleanliness. Suction strainers or filters should be installed in all systems to prevent entry of large contaminants into pump.

Purpose of a suction strainer or filter is for protection of internal pumping elements. It should be installed immediately ahead of inlet port. This location should provide for easy cleaning or replacement of strainer element.

1. Install a strainer or filter in suction pipe. Ensure size and capacity of strainer or filter is adequate to prevent having to clean or replace elements too frequently. General guidelines for strainer sizing are as follows:

**Table 4 General Guidelines for Strainer or Filter Sizing**

| Liquid   | Use Mesh Size   |
|--|---|
| Relatively clean viscous liquids, over 5000 SSU  | 10 to 12 mesh screens or those with about 1/16 inch (1.5 mm) openings                               |
| Relatively clean light liquids such as distillate fuels, hydraulic oil and light lube oils | 100 to 200 mesh screens   |
| Heavy crude oils   | 5 to 6 mesh strainer screens or those with or about 1/8 inch (3 mm) openings                        |
| Relatively clean distillate fuels in high pressure fuel supply systems                     | For three screw pumps: 25 micron "absolute" filters<br>For gear pumps: 10 micron "absolute" filters |

2. Monitor strainer / filter by installing appropriate gages or instrumentation. Pressure drop across a dirty strainer must not allow inlet pressure to fall below NPIPR.

**Figure 8 – Ideal Strainer Arrangement**

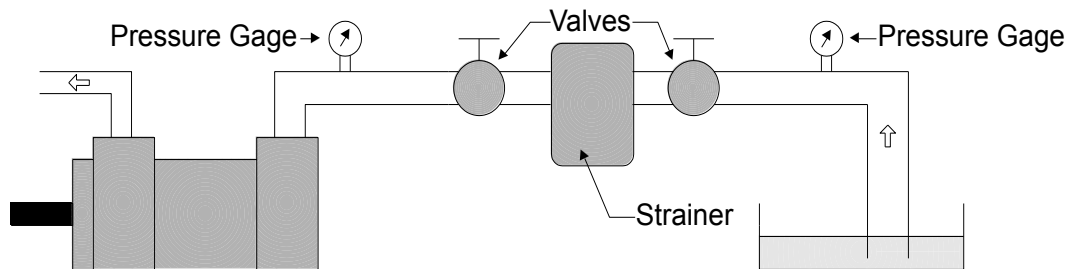

### 3.6.5. System Filtration

For systems that recirculate pumped liquid, install downstream (pressure or return side) filtration. Downstream filters may also be required to protect components such as servo valves in hydraulic systems or high-pressure fuel nozzles and flow dividers in fuel oil supply systems for gas turbines.

System's most contamination-sensitive component determines its liquid cleanliness requirement.

**Table 5 Downstream Filter Recommended Sizing**

| Liquid and Condition   | Recommended Downstream Filter Size                   |
|--|--|
| Fuel oil, light lube oil, hydraulic oil, other relatively low viscosity (thin) liquids | High efficiency 10 micron "absolute" or finer filter |
| Extreme operating conditions or harsh environments.                                    | High efficiency 10 micron "absolute" or finer filter |
| Clean viscous liquids in moderate environment  | 25 micron "nominal" filter                           |
| Water-thin low lubricity or unusually large number of contaminants                     | Contact manufacturer                                 |

System builder determines filter size (dirt holding capacity) by amount and size of contamination expected to be produced by system and other external contamination sources, by allowable pressure drop across filter and by acceptable frequency for cleaning and replacing filter elements.

### 3.6.6. Outlet Piping

Outlet piping should be sized to accommodate pump's flow rate while minimizing pipe friction losses. Outlet piping should be designed to prevent gas and air pockets. Piping downstream of pump should include a vent at highest point in system to allow air to escape during priming.

## 3.7. Connecting Pipes

### 3.7.1. Keeping Pipes Clean

| NOTE   |
|--|
| <p><b>Material damage caused by debris in piping entering pump!</b></p> <ul style="list-style-type: none"><li>- Before connecting pump to system, flush all system piping thoroughly to remove debris accumulated during fabrication, storage, and installation.</li><li>- Do not use lmo pumps for flushing.</li><li>- Ensure suction line between suction strainer and pump is clean</li></ul> |

1. Flush all pipe parts and fittings prior to assembly.
2. Ensure no flange seals protrude inward.
3. Remove any blank flanges, plugs, protective foils, and/or protective paint from flanges.
4. On welded pipes, remove welding beads.

### 3.7.2. Installing Suction Piping

1. Remove port covers from pump.
2. To avoid air pockets:
  - For inlet piping, run pipes with a continuous downward slope to pump.

### 3.7.3. Installing Discharge Piping

1. Remove port covers from pump.
  - Install discharge pipe.

### 3.7.4. Ensuring Stress Free Pipe Connections

Piping installed and cooled down

| NOTE  |
|---|
| <p><b>Material damage due to distorted pump casing!</b></p> <ul style="list-style-type: none"><li>- Ensure that all pipes are stress free when connected to pump.</li></ul> |

Disconnect pipe connecting flanges from pump.

Check whether pipes can be moved freely in all directions within expected range of expansion:

- Nominal diameter less than 6 inch (150 mm): by hand
- Nominal diameter greater than 6 inch (150 mm): with a small lever

1. Make sure flange surfaces are parallel.
2. Reconnect pipe flanges to pump.



### 3.8. Shaft Packing and Seal Leakage

Pump should be installed so any leakage from shaft packing or shaft seal does not become a hazard. Packing leakage should be about 8 to 10 drops/minute. A small amount of liquid may also leak from mechanical or lip seals (usually less than or equal to 10 drops/hour). Provisions should be made to collect leakage from packing or shaft seals.

#### WARNING

##### **Risk of injury and poisoning due to hazardous pumped liquids!**

- Safely collect any leaking pumped liquid, then discharge and dispose of it in accordance with environmental regulations.

1. Provide equipment for collecting and discharging leaking liquids.
2. Ensure free discharge of leaking liquids.

### 3.9. Quenched Shaft Seals

Some pumps include quenched mechanical shaft seals. For these pumps, a low pressure stream of steam or nitrogen is supplied from an external source to atmospheric side of seal faces.

Quenching is used in selected seal applications to:

- Heat or cool seal area
- Prevent build-up of coke formations by excluding oxygen
- Flush away undesirable material build-up around dynamic seal components

If quenched mechanical seals are part of pump assembly:

1. Determine quench connection size and port locations
2. Supply an appropriate seal quench stream.

### 3.10. Gages

1. Monitor pumps operating conditions with easily readable pressure and temperature gages.
2. Gages should be placed as close as possible to pumps inlet and outlet flanges.

### 3.11. Ideal Installation for Pumps Located Above Liquid Level

**Figure 9 Vertical Mounted Pump**

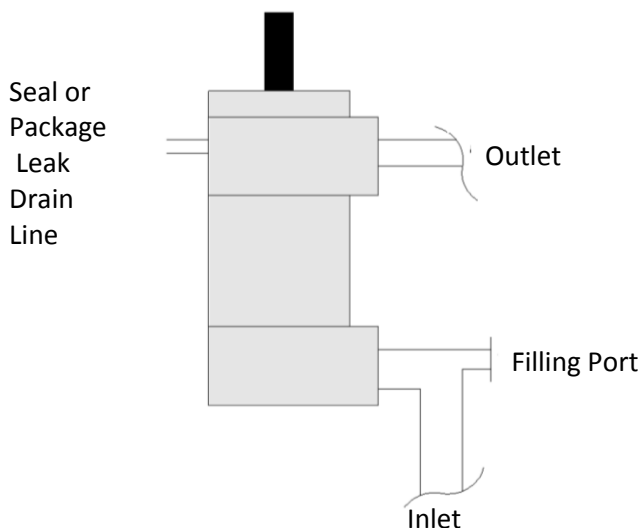

**Figure 10 Horizontal Mounted Pump**

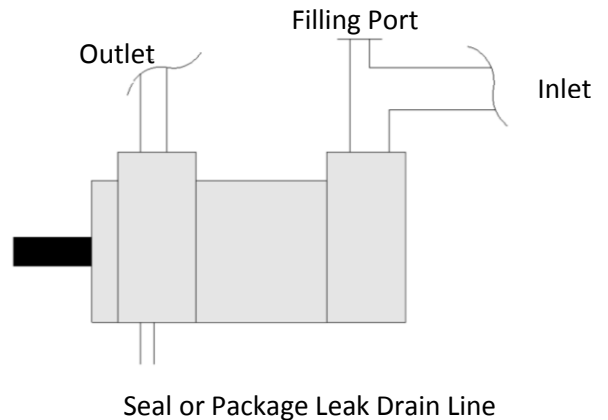

### 3.12. Electrical Connections

|  |
|--|
|  <b>DANGER</b>                      |
| <b>Risk of death due to electric shock!</b><br>- Have all electrical work carried out by qualified electricians only |

#### Connecting motor

Verify electrical requirements for driver match electrical supply with respect to voltage, number of phases and terminal connections. Follow instructions of motor manufacturer.

1. Connect motor according to connection diagram supplied by motor manufacturer.
2. Make sure no danger arises due to electric power.
3. Install an EMERGENCY STOP

## 4. Startup, Operation and Shutdown

See Atex instructions for pumps in explosion-hazard areas

In closed or recirculating systems:

1. Check liquid level in tank before and after start-up to be sure it is within operating limits.
2. If initial liquid level is low, or if it drops as system fills during start-up or pumping operations, add sufficient clean liquid to tank to bring liquid to its normal operating level.
3. Check condition of liquid regularly. Follow supplier's recommendations for maintaining liquid and establishing when liquid is to be changed.
4. Control temperature of liquid. Liquid should not fall below its minimum allowable viscosity that occurs at maximum operating temperature.
5. Ensure that maximum viscosity at cold start-up does not cause pump inlet pressure to fall below minimum required value.

### 4.1. Putting Pump in Service

#### 4.1.1. Removing Preservative

On pumps treated for storage, remove preservative

#### 4.1.2. Protective Devices

Automatic shutdowns, emergency switches, and similar controls should be part of pumping system. They are generally supplied by system supplier or user.

|  |
|--|
|  <b>DANGER</b>  |
| <b>Risk of death or injury due to accidental contact with rotating parts!</b><br>- Install covers or guards over bracket openings on flange mounted pumps.<br>- Install covers or guards over couplings and shafts on foot mounted pumps.<br>- Install covers or guards over sheaves, gears, chains, belts or other type drives. |

**! WARNING**

**Risk of injury and material damage due to blocked discharge line!**

- Provide adequate relief protection to avoid danger to personnel and catastrophic failure

Before start-up, ensure all protective covers and guards are in place. Check all valves, especially those that are manually operated, to be sure they are in proper position.

Ensure suction and discharge line are not blocked. Pressure relief valves supplied by manufacturer are pre-set. Make sure safety valve on system side meets requirements of pump.

### 4.1.3. Filling and Bleeding

**NOTE**

**Risk of injury and poisoning due to hazardous pumped liquids!**

- Safely collect any leaking pumped liquid and dispose of it in accordance with environmental rules and requirements.

**! WARNING**

**Risk of injury due to hot pumped liquids!**

- Avoid skin contact when operating temperatures exceed 140°F (60°C).

1. Pour some liquid to be pumped into fill point (priming point) in system or directly into pump suction port.
2. Rotate pump slowly by hand until rotors or gears (pumping elements) are wet and suction line is as full of liquid as possible.

**Figure 11 Priming Point (Fill Point)**

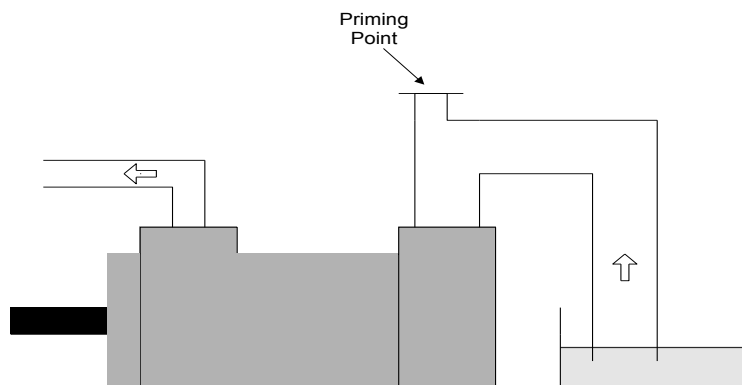

Fill seal chamber with pumped liquid to ensure mechanical seal does not start dry. This can be done by removing seal vent set-screw and pouring fluid into seal chamber vent before opening pump inlet. Alternately, the seal chamber can be vented in situations where the inlet pressure is above atmospheric, by opening the inlet and discharge valves and then loosening the seal vent-plug to allow the suction pressure to push out the air in the seal chamber until oil flows from it.

#### 4.1.4. Intermediate Drive Lubrication

Some pump units include intermediate gearboxes or other devices between pump and driver. When these devices are present, lubrication is required.

Add lubricant to specified level per device manufacturer's recommendations before start-up.

#### 4.1.5. Heating Jackets

Pump may require heating before start-up. Heating is typically accomplished with steam, heat transfer fluid or electric heat strips. Pump may be fitted with a heating jacket.

If electric heating is used:

- Fill jacket with appropriate heat transfer fluid prior to start-up.
- Maximum permissible pressure in a heating jacket is 150 psi gage unless operating instructions specify otherwise.

#### 4.1.6. Shaft Seal Quenching Fluid

Apply steam to seal at least 30 minutes prior to pump start-up to ensure seal area is thoroughly heated. Quenching steam should be saturated at about 4 to 7 psi (275 to 480 mBar) gage. Apply nitrogen quenching fluid just prior to pump start up.

#### 4.1.7. Checking Rotation Direction

- Be sure pump is filled and bled
- Be sure coupling is installed
- Be sure pump shaft and driver are aligned
- Be sure pump turns freely by hand

|   |
|---|
|  <b>DANGER</b>   |
| <b>Risk of death due to rotating parts!</b> <ul style="list-style-type: none"><li>- Use personal protective equipment when carrying out any work on pump.</li><li>- Keep an adequate distance from rotating parts</li></ul> |

|  |
|--|
| <b>NOTE</b>  |
| <b>Material damage caused by dry running!</b> <ul style="list-style-type: none"><li>- Make sure the pump is filled properly.</li></ul> |

|  |
|--|
| <b>NOTE</b>  |
| <b>Material damage caused operating pump in reverse direction!</b> <ul style="list-style-type: none"><li>- Make rotation direction matches direction of rotation arrow</li></ul> |

1. Check rotation direction arrow cast on pump casing or located on rotation nameplate on pump to determine intended direction of rotation. Ensure rotation direction arrow is not confused with inlet or outlet flow direction arrows.

**Fig. 12 Rotation Arrow Location**

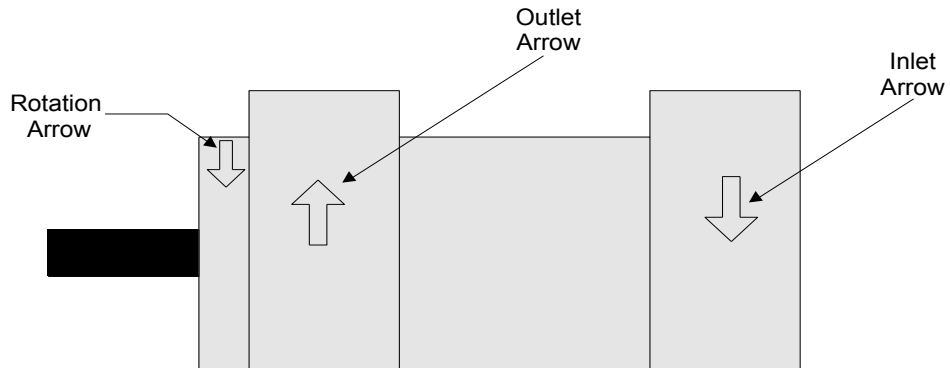

2. Switch motor on and immediately off again.
3. Make sure motor turns in direction indicated by pump rotation arrow.
4. If rotation is different: swap motor electrical connections to swap phases.
5. Recheck motor rotation.

#### **4.1.8. Switching On**

Pump set up and connected properly  
 Motor set up and connected properly  
 All connections stress-free and sealed  
 All safety equipment installed and tested for functionality  
 Pump prepared, filled and bled properly  
 Pump and motor rotation checked.  
 Sufficient filling level in container (minimum immersion depth)

|   |
|---|
| <b>⚠ DANGER</b>   |
| <b>Risk of injury due to running pump or hot pump parts!</b>  |
| <ul style="list-style-type: none"> <li>- Do not touch the running pump.</li> <li>- Ensure that the coupling guard is attached.</li> <li>- Do not carry out any work on running pump.</li> <li>- Stop pump and allow pump to cool down completely before starting any work.</li> </ul> |

|   |
|---|
| <b>⚠ DANGER</b>   |
| <b>Risk of injury and poisoning due to pumped liquid spraying out!</b>  |
| <ul style="list-style-type: none"> <li>- Use personal protective equipment when carrying out any work on pump.</li> </ul> |

|  |
|--|
| <b>NOTE</b>  |
| <b>Risk of cavitation when throttling down suction flow rate!</b>  |
| <ul style="list-style-type: none"> <li>- Fully open the suction-side fitting and do not use it to adjust flow rate.</li> </ul> |

|  |
|--|
| <b>NOTE</b>  |
| <b>Material damage due to excessive pressure!</b>  |
| <ul style="list-style-type: none"> <li>- Do not operate pump while pressure-side fitting is closed.</li> </ul> |

|  |
|--|
| <b>NOTE</b>  |
| <b>Material damage caused by dry running!</b>  |
| <ul style="list-style-type: none"> <li>- Make sure pump is filled properly.</li> </ul> |

1. Open pressure-side fitting.
2. Open suction-side fitting.
3. Switch on motor and make sure it is running smoothly.
4. Make sure minimum pumping pressure is above 40 psig
5. Make sure differential pressure across pump is at least 40 psi.
6. Listen for unusual noise or vibration
8. After first load under pressure and at operating temperature, check pump is not leaking

#### 4.1.9. Shaft Seal Leakage

Pumps with packing-type seals must be checked to ensure packing gland is not too tight. Excessive gland pressure on packing will cause a scored shaft, overheating and rapid breakdown of packing. Keep gland nuts only finger tight. After new packing has been installed, gland nuts should be tightened evenly but only tight enough to seat packing rings properly. Then loosen gland nuts and re-tighten finger tight. Final adjustment should allow a leakage of approximately 10 drops per minute while pump is operating. Leakage is necessary to lubricate packing. Provide a place for safe draining and disposal of leakage.

#### 4.1.10. Thermal Shock and Operating Temperature Limits

| NOTE  |
|---|
| <p><b>Material damage caused by thermal shock or operation outside of temperature limits.</b></p> <ul style="list-style-type: none"> <li>- Do not operate outside of minimum or maximum allowable pump or liquid temperature limits.</li> <li>- Do not expose equipment to thermal shock.</li> <li>- Use insulation, heating jacket, or heat tracing to maintain pump at liquid temperature in high temperature applications</li> </ul> |

- During start-up, as well as during operation, thermal shock (temperature of liquid entering pump relative to pump body temperature) should be within  $\pm 50$  °F (28 °C).
- Unless approved by Imo, maximum rate of temperature change during pump heating or cooling should be about 15 °F/minute (8½ °C/minute) for pump with iron or Babbitt-lined steel rotor housing and 3 °F (1.7 °C) for pumps with bronze-lined housings.
- A pump used in a system where fluid is heated or cooled more than 50 °F from pump ambient temperature before pump is started up should be preheated or cooled and temperature maintained for at least 30 minutes prior to start-up. This will assure pump will not be thermally shocked and will have a uniform temperature distribution throughout before it is run.
- Unless approved by Imo, liquids entering pump inlet must not be hotter than 225 °F (107 °C) nor colder than 0 °F (-18°C) for pumps with Iron or Babbitt-lined steel rotor housings. The upper limit for pumps with bronze rotor housings is 180 °F (82 °C).

| NOTE  |
|---|
| <p><b>Material damage caused by thermal shock!</b></p> <ul style="list-style-type: none"> <li>- Never exceed thermal shock limit or minimum/maximum allowable pump or liquid temperature without specific approval from Imo Pump. Differences in metallurgy and their respective coefficients of thermal expansion could cause distortion of part parts resulting in breakdown condition. External pump insulation and heating jacket or heat tracing is recommended in high temperature applications to maintain pump at liquid temperature</li> </ul> |

#### 4.1.11. Switching Off

|   |
|---|
|  <b>WARNING</b>                        |
| <b>Risk of injury due to hot pump parts!</b><br>- Use personal protective equipment when carrying out any work on pump. |

1. Switch off motor.
2. After initial start-up; check all tie bolts and tighten them if necessary.

#### 4.2. Shutting Down Pump

|  |
|--|
|  <b>WARNING</b>   |
| <b>Risk of injury and poisoning due to hazardous pumped liquid!</b><br>- Safely collect any leaking pumped liquid and dispose of it in accordance with environmental rules and requirements. |

Take following measures whenever pump is shut down:

**Tab. 8 Measures to be taken if pump is shut down**

| Pump is                           | Measure   |
|-----------------------------------|---|
| Shut down for a prolonged period. | ➤ Take measures according to pumped liquid  |
| Emptied                           | ➤ Close suction-side and pressure-side fittings.                                    |
| Removed from motor                | ➤ Isolate motor from its power supply and secure it against unauthorized switch-on. |
| Put into storage                  | ➤ Follow storage instructions.  |

**Table 9 Measures Depending on Characteristics of Pumped Fluid**

| Characteristics of Pumped Liquid    | Duration of Shutdown                    |  |
|-------------------------------------|---|--|
|                                     | Short Term                              | Long Term  |
| Solidify                            | ➤ Flush pump.                           | ➤ Flush pump.  |
| Solidifying/freezing, non-corrosive | ➤ Heat up or empty pump and containers. | ➤ Empty pump and containers.   |
| Solidifying/freezing, corrosive     | ➤ Heat up or empty pump and containers. | ➤ Empty pump and containers.<br>➤ Treat pump and containers with preservative. |
| Remains liquid, non-corrosive       |   |  |
| Remains liquid, Corrosive           |   | ➤ Empty pump and containers.<br>➤ Treat pump and containers with preservative. |

### 4.3. Start-up Following a Shutdown Period

1. If pump is shut down for over 6 months, take following measures before starting it up again:
  - Replace elastomer seals (O-rings, shaft seal rings).
  - Replace antifriction bearings.
  - If necessary, replace motor bearing.
2. Carry out all steps in **Operation** section 4 above.

### 4.4. Operating Standby Pump

#### Stand-by pump filled and bled

Operate stand by pump at least once a week.

## 5. Maintenance

For pumps in explosion-hazard areas see additional ATEX instructions (SRM00097).

Trained service technicians are available for fitting and repair work. Present pumped liquid certificate (DIN safety data sheet or MSDS sheet) when requesting service.

### 5.1. Inspection

Inspection intervals depend on operating conditions of pump.

|   |
|---|
|  <b>DANGER</b>   |
| <b>Risk of injury due to accidental contact with running pump or hot pump parts!</b> <ul style="list-style-type: none"><li>- Do not touch running pump.</li><li>- Do not carry out any work on running pump.</li><li>- Stop pump and allow pump to cool down completely before starting any work.</li></ul> |

|  |
|--|
|  <b>WARNING</b>   |
| <b>Risk of injury and poisoning due to hazardous pumped liquids!</b> <ul style="list-style-type: none"><li>- Use personal protective equipment when carrying out any work on pump.</li></ul> |

1. Check at appropriate intervals:
  - Temperature of roller bearings.
  - Normal operating conditions unchanged
  - Pressure relief valve is working
2. For trouble-free operation, always ensure following:
  - No dry running
  - No leaks
  - No cavitation
  - Suction-side gate valves open
  - Unclogged and clean filters
  - Sufficient pump ingress pressure
  - No unusual running noises or vibrations
  - No excessive leakage at shaft seal
  - Foundation and hold-down bolts tight





## 5.2. Maintenance

Pump environment, operating conditions and intervals between bearing checks all effect antifriction bearing service life. Antifriction bearings are designed for greater than 2 years service life when operation conditions are within permissible range.

Mechanical seals are subject to natural wear, which strongly depends on operating conditions. Therefore, general statements regarding their service life cannot be made.

|   |
|---|
|  <b>DANGER</b>                     |
| <b>Risk of death due to electric shock!</b><br>Have all electrical work carried out by qualified electricians only. |

|  |
|--|
|  <b>DANGER</b>  |
| <b>Risk of injury due to accidental contact with running pump, hot pump parts, or electrical connections!</b>  |
| <ul style="list-style-type: none"><li>- Do not touch running pump.</li><li>- Do not carry out any work on running pump</li><li>- Stop pump and allow pump to cool down completely before starting any work</li><li>- Isolate motor from its supply voltage and secure it against being switched back on again before all assembly and maintenance work.</li><li>- Shut, wire or chain and lock all valves in pump inlet/outlet piping</li><li>- If applicable, shut off any steam or other fluid supply lines to pump.</li></ul> |

|   |
|---|
|  <b>WARNING</b>  |
| <b>Risk of injury and poisoning due to hazardous pumped liquids!</b>  |
| <ul style="list-style-type: none"><li>- Use personal protective equipment when carrying out any work on pump.</li><li>- Stop pump and allow it to cool down completely before starting any work.</li><li>- Make sure pump is depressurized.</li><li>- Empty pump and safely collect pumped liquid. Dispose of it in accordance with environmental rules and requirements.</li></ul> |

### 5.2.1. Antifriction Bearings

|  |
|--|
| <b>NOTE</b>  |
| <b>Material damage caused by continued running with rough or worn bearings!</b>          |
| <ul style="list-style-type: none"><li>- Replace bearings when worn or damaged.</li></ul> |

1. As a precautionary measure, replace antifriction bearing every 2 years (recommended).
2. Replace bearings immediately if rough operation or increased bearing temperature is detected.
3. When grease or oil fittings are provided, lubricate bearings.

### 5.2.2. Mechanical Seals, Gaskets, O-rings

Mechanical seals have functional leaks.

1. Ensure pump installation allows periodic replacement of shaft seals, gaskets, or O-rings.

2. Ensure all connections involving shaft seals, auxiliary seals, gaskets, or O-rings are tight.
3. If leakage is more than 10 drops per hour per seal, shut down equipment and repair or replace necessary parts.

### 5.2.3. Packing

Repack pump when all packing gland travel is exhausted or when packing gland is damaged.

### 5.2.4. Filters and Strainers

Clean or replace all filter and strainer elements when dirty or clogged.

### 5.2.5. Alignment

Check and correct alignment of pump and its driver at least every 6 months. Check more frequently if system experiences vibration or large variations in temperature.

### 5.2.6. Cleaning Pump

|   |
|---|
| <b>NOTE</b>   |
| <b>Bearing damage caused by high water pressure or spray water!</b><br>- Do not clean bearing areas with a water or steam jet |

Clean large-scale grime from pump.

## 5.3. Repairs

Manufacturer maintains a staff of trained service personnel that can provide pump installation, pump start-up, maintenance-overhaul and troubleshooting supervision as well as installation and maintenance training.

|   |
|---|
|  <b>DANGER</b>                     |
| <b>Risk of death due to electric shock!</b><br>- Have all electrical work carried out by qualified electricians only. |

|   |
|---|
|  <b>DANGER</b>   |
| <b>Risk of injury due to accidental contact with running pump, hot pump parts, or electrical connections!</b><br>- Do not touch running pump.<br>- Do not carry out any work on running pump<br>- Stop pump and allow to cool-down completely before starting any work.<br>- Isolate motor from its supply voltage and secure it against being switched back on again before all assembly and maintenance work.<br>- Shut, wire or chain and lock all valves in pump inlet/outlet piping.<br>- If applicable, shut off any steam or other fluid supply lines to pump. |

|  |
|--|
|  <b>WARNING</b>   |
| <b>Risk of injury and poisoning due to hazardous pumped liquids!</b>   |
| <ul style="list-style-type: none"> <li>- Use personal protective equipment when carrying out any work on pump.</li> <li>- Stop pump and allow to cool down completely before starting any work.</li> <li>- Make sure pump is depressurized</li> <li>- Empty pump and safely collect pumped liquid.</li> <li>- Dispose of it in accordance with environmental rules and requirements</li> </ul> |

|   |
|---|
|  <b>WARNING</b>  |
| <b>Risk of injury due to heavy components!</b>  |
| <ul style="list-style-type: none"> <li>- Pay attention to component weight.</li> <li>- Lift and transport heavy components using suitable lifting gear</li> <li>- Set down components safely and secure them against overturning or rolling away</li> </ul> |

### 5.3.1. Returning Pump to Manufacture

Manufacturer provides maintenance as well as overhaul and a test facility in event user prefers to return pumps to factory for inspection or overhaul. Pumps that have been factory overhauled are normally tested and warranted “as-new” for a period of one year from date of shipment.

Take necessary measures, depending on required repair work, as listed in table below when returning pump to manufacturer.

**Table 10 Measures for Returning Pump**

| Repairs   | Measure for Return  |
|---|---|
| At customer’s premises                          | Return defective component to manufacturer.                               |
| At manufacturer’s premises                      | Flush pump and decontaminate if it was used for hazardous pumped liquids. |
| At manufacturer’s premises for warranty repairs | Return complete pump (not disassembled) to manufacturer.                  |

### 5.3.2. Removing Pump

Pump depressurized. Pump completely empty, flushed and decontaminated  
 Electrical connections disconnected and motor secured against being switched on again  
 Pump cooled down. Coupling guard removed On couplings with spacer piece: Spacer piece removed  
 Auxiliary systems shut down, Depressurized and emptied. Unhook pressure lines, gages

|   |
|---|
|  <b>WARNING</b>  |
| <b>Risk of injury during disassembly!</b>   |
| <ul style="list-style-type: none"> <li>- Secure pressure-side gate valve against accidental opening.</li> <li>- Depressurize locking pressure system, if available.</li> <li>- Wear protective gloves as components can become very sharp through wear or damage.</li> <li>- Remove spring-loaded components carefully (e.g. mechanical seal) as components can be ejected by spring tension.</li> <li>- Observe manufacturer’s specifications (e.g. for motor, coupling, mechanical seal, blocking pressure system, drive shaft, drives, belt drive etc.)</li> </ul> |

1. Observe following during removal:
  - Mark precise orientation and position of all components before dismounting them.
  - Remove parts without cocking.
2. Remove pump.

### 5.3.3. Servicing Pump

**Refer to product service manual for specific pump for pump disassembly and reassembly.**

### 5.3.4. Ordering Spare Parts

For trouble-free replacement in event of faults, keep a supply of complete spare pumps or repair kits available on site (recommended).

Parts that can be replaced can be found in pump parts list in pump specific manual. Purchase of repair kits is preferred over selecting individual parts in order to prevent overlooking necessary components or mixing worn parts with new parts.

Minor Repair Kits are used to repair leaking seals, bad bearings, and items required for re-assembly after teardown. Minor Kits include pump shaft seals, packing, and all O-rings, gaskets and bearings. Major Repair Kits are sufficient to rebuild completely worn-out pumps to “as-new” condition. Major Repair Kits include all parts found in Minor Repair Kits plus all major internal parts subject to wear.

**Have following information ready to hand when ordering spare parts:**

- Pump type                      Pump number    Year of manufacture
- Part number Designation Quantity

## 6. Troubleshooting

### 6.1. Pump Malfunctions

If malfunctions occur that are not specified in following table or cannot be traced to specified causes, please consult manufacturer.

| <b>Malfunction</b>                  | <b>Cause</b>  | <b>Remedy</b>   |
|-------------------------------------|---|---|
| <b>Loss of Flow or Low Capacity</b> | System component malfunction  | <ul style="list-style-type: none"> <li>- Inspect all system components.</li> <li>- Correct any malfunctions.</li> <li>- Ensure that suction and discharge lines are open and all valves are in proper positions.</li> </ul>                             |
|                                     | Pump not primed or vented   | <ul style="list-style-type: none"> <li>- Check reservoir oil level and fill as required.</li> <li>- Vent air from pump.</li> </ul>  |
|                                     | Low pump speed  | <ul style="list-style-type: none"> <li>- Ensure driver is not overloaded.</li> <li>- For belt drives, ensure belt is not slipping.</li> <li>- For variable speed drivers or variable speed intermediate devices, ensure proper speed is set.</li> </ul> |
|                                     | Incorrect pump rotation   | <ul style="list-style-type: none"> <li>- Correct direction of rotation</li> </ul>   |
|                                     | Supply/suction pipe, pump or suction strainer blocked or encrusted. | <ul style="list-style-type: none"> <li>- Clean supply/suction pipe, pump or suction strainer.</li> <li>- Remove any blockage.</li> </ul>  |

|  |   |  |
|--|---|--|
|  | Wear of rotors and/or housings          | - Replace worn rotors, gears, and/or housings.   |
|  | System bypass problem                   | - Check all system bypass valves, including relief valve.<br>- Repair or replace as required.  |
|  | Insufficient inlet pressure.            | - Clean supply/suction pipe, pump or suction strainer. - - Remove any blockage.  |
| <b>Loss of Suction</b>                         | Suction line closed, blocked or leaking | - Verify suction line valve is locked open.<br>- Inspect suction line, especially joints. Remove any obstruction and repair any leaks.<br>- Clean strainer or replace filter.                                      |
|  | Excessive viscosity                     | - Reduce viscosity by heating pump and/or system liquids.  |
|  | Dirty suction strainer                  | - Clean or replace strainer or filter element.   |
|  | Incorrect pump rotation                 | - Correct direction of rotation.   |
| <b>Low Discharge Pressure</b>                  | Low liquid level in reservoir           | - Check reservoir oil level and fill as required.  |
|  | Air in system                           | - Ensure pump is vented.<br>- Ensure suction lines are full of liquid.   |
|  | Worn rotors, gears, and/or housings     | - Replace worn rotors, gears, and/or housings.   |
|  | Obstruction in piping                   | - Clean the supply/suction pipe. Remove any blockage.  |
|  | Dirty suction strainer                  | - Clean the suction strainer.  |
|  | System bypass problem                   | - Check all system bypass valves, including relief valve. Repair or replace as required.   |
| <b>Excessive or Unusual Noise or Vibration</b> | Misalignment                            | - Check pump and driver alignment. Correct alignment as required.  |
|  | Restricted suction line                 | - Clean the supply/suction pipe. Remove any blockage.  |
|  | Air in system                           | - Ensure pump is vented.<br>- Ensure suction lines are full of liquid.<br>- Check reservoir oil level and fill as required<br>- Check all lines, flanges, joints and connections for leakage. Repair as necessary. |
|  | Dirty suction strainer                  | - Clean the suction strainer.  |
|  | Relief valve chatter or leakage         | - Check discharge relief valve pressure setting. Re-adjust, repair, or replace relief valve  |
|  | Heavy rubbing of internal pump parts    | - Check pump and driver alignment. Correct alignment as required.<br>- Inspect pump wearing parts. Replace as required.  |
|  | Mechanical problem                      | - Check for loose or mis-positioned coupling.<br>- Check for bent or broken shafts.<br>- Check for worn bearing. Replace or repair as necessary.   |
|  | <b>Rapid Pump Wear</b>                  | Fluid contains abrasive foreign matter   |

|                              |   |   |
|------------------------------|---|---|
|                              |   | <ul style="list-style-type: none"> <li>- Reduce downstream filter ratings in re-circulating systems (do not exceed NPIPR).</li> <li>- If necessary, replace liquid in re-circulating systems.</li> </ul>              |
|                              | Fluid contains water                                  | <ul style="list-style-type: none"> <li>- Remove any water from reservoir. Find source and prevent further contamination.</li> </ul>   |
|                              | Misalignment  | <ul style="list-style-type: none"> <li>- Check pump and driver alignment. Correct alignment as required.</li> </ul>   |
|                              | Insufficient liquid                                   | <ul style="list-style-type: none"> <li>- Check liquid level in reservoir and correct as required.</li> <li>- Remove any suction line obstructions.</li> <li>- Clean or replace strainer or filter element.</li> </ul> |
| <b>Excessive Power Usage</b> | Fluid more viscous than specified                     | <ul style="list-style-type: none"> <li>- Heat fluid to proper viscosity and or design temperature.</li> </ul>   |
|                              | Pump suction and/or discharge lines closed or blocked | <ul style="list-style-type: none"> <li>- Ensure suction and discharge lines are open, and remove obstructions if present.</li> </ul>  |
|                              | Heavy rubbing of internal pump parts                  | <ul style="list-style-type: none"> <li>- Check pump and driver alignment. Correct alignment as required.</li> <li>- Inspect pump wearing parts. Replace as required.</li> </ul>                                       |
|                              | Excessive pump speed                                  | <ul style="list-style-type: none"> <li>- Reduce pump speed to design limits.</li> </ul>   |
|                              | Mechanical problem                                    | <ul style="list-style-type: none"> <li>- Check for loose or mis-positioned coupling, bent or broken shafts, or worn bearing.</li> <li>- Replace or repair as necessary.</li> </ul>                                    |

## 6.2. Relief Valve Malfunctions

| <b>Malfunction</b>                          | <b>Cause</b>                          | <b>Remedy</b>  |
|---|---------------------------------------|--|
| <b>Pumping Pressure Drops</b>               | Spring worn out                       | <ul style="list-style-type: none"> <li>- Install new spring.</li> </ul>  |
|   | Valve seat leaks                      | <ul style="list-style-type: none"> <li>- Install new valve cone</li> <li>- Vent air from pump.</li> </ul>  |
| <b>Pressure Relief Valve Does Not Open</b>  | Spring tension too high               | <ul style="list-style-type: none"> <li>- Relieve the pressure on the spring by turning the adjusting screw, then reset the pressure relief valve.</li> </ul>   |
|   | Foreign particles in the valve        | <ul style="list-style-type: none"> <li>- Remove the pressure relief valve.</li> <li>- Clean the internal parts.</li> <li>- Install the pressure relief valve.</li> </ul>   |
|   | Pump operating temperature too high   | <ul style="list-style-type: none"> <li>- Consult the manufacturer.</li> </ul>  |
| <b>Pressure Relief Valve Does Not Close</b> | Spring has no/or insufficient tension | <ul style="list-style-type: none"> <li>- Reset pressure relief valve</li> </ul>  |
|   | Valve seat leaks                      | <ul style="list-style-type: none"> <li>- Install new valve cone</li> <li>- Vent air from pump.</li> </ul>  |
| <b>Pressure Relief Valve Rattles</b>        | Pressure relief valve rattles         | <ul style="list-style-type: none"> <li>- Measure the excess pressure with the fitting on the pressure side closed.</li> <li>- Reset the pressure relief valve (opening pressure 10% higher than the operating pressure)</li> </ul> |

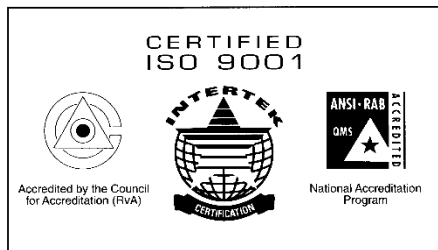

**CIRCOR**

1710 Airport Road

P.O. Box 5020

Monroe, NC USA

28111.5020

Tel: 704.289.6511

Website: [www.circorpt.com](http://www.circorpt.com)

e-mail: [cc@circor.com](mailto:cc@circor.com)

